



# AGENDA

## BOARD OF SUPERVISORS, COUNTY OF MONO STATE OF CALIFORNIA

Teleconference Only - No Physical Location

**Special Meeting**  
**March 26, 2020**

---

### TELECONFERENCE LOCATIONS:

As authorized by Governor Newsom's Executive Order, N-29-20, dated March 17, 2020, the meeting will be held via teleconferencing with members of the Board attending from separate remote locations. The meeting will be livecast from the following location: Mono County Courthouse, Board Chambers 2nd Floor, 278 Main St., Bridgeport, CA., 93517. This altered format is in observance of recent recommendations by local officials that certain precautions be taken, including social distancing, to address the threat of COVID-19.

#### **Important Notice to the Public Regarding COVID-19**

Based on guidance from the California Department of Public Health and the California Governor's Officer, in order to minimize the spread of the COVID-19 virus, please note the following:

1. There is no physical location of the meeting open to the public. You are strongly encouraged to observe the live stream of the Board of Supervisors meetings at [http://monocounty.granicus.com/MediaPlayer.php?publish\\_id=8c4d8d56-9aa6-4b8a-ace3-1fbaaecbf14a](http://monocounty.granicus.com/MediaPlayer.php?publish_id=8c4d8d56-9aa6-4b8a-ace3-1fbaaecbf14a)
2. If you wish to make a comment on a specific agenda item before the meeting, please submit your comment via email by 5:00 p.m. on the day prior to the Board meeting. Please submit your comment to the Deputy Clerk of the Board Scheereen Dedman at [sdedman@mono.ca.gov](mailto:sdedman@mono.ca.gov). Your comment will be placed into the record at the Board meeting.
3. If you are watching the live stream of the Board meeting and wish to make either a general public comment or to comment on a specific agenda item as it is being heard, please submit your comment, limited to 250 words or less, to the Deputy Clerk of the Board Scheereen Dedman at [sdedman@mono.ca.gov](mailto:sdedman@mono.ca.gov). Every effort will be made to read your comment into the record, but some comments may not be read due to time limitations. Comments received after an agenda item will be made part of the record if received prior to the end of the meeting.

**NOTE:** In compliance with the Americans with Disabilities Act if you need special assistance to participate in this meeting, please contact Shannon Kendall, Clerk of the Board, at (760) 932-5533. Notification 48 hours prior to the meeting will enable the County to make reasonable arrangements to ensure accessibility to this meeting (See 42 USCS 12132, 28CFR 35.130).

**ON THE WEB** You can view the upcoming agenda at <http://monocounty.ca.gov>. If you would like to receive an automatic copy of this agenda by email, please subscribe to the Board of Supervisors Agendas on our website at <http://monocounty.ca.gov/bos>.

9:00 AM      Call meeting to Order

Pledge of Allegiance

**1            OPPORTUNITY FOR THE PUBLIC TO ADDRESS THE BOARD**

on items of public interest that are within the subject matter jurisdiction of the Board.  
(The clerk will read comments received via email at this time.)

## 2. **AGENDA ITEMS**

### A. **Review and Declaration of Election Results**

Departments: Elections

10 minutes (5 minute presentation; 5 minute discussion)

(Shannon Kendall, Registrar of Voters) - Presentation of certified election results. Request for declaration of results. To view the complete Statement of Votes Cast (that will be submitted to the Secretary of State electronically), visit <https://monocounty.ca.gov/elections/page/march-3-2020-primary-election-results>

**Recommended Action:** Approve as correct the Statement of Votes for the March 3, 2020 Presidential Primary Election and Declare elected to office the following candidates who received the highest number of votes in each contest of the Election: Bob Gardner for Mono County Supervisor, District 3; John Peters for Mono County Supervisor, District 4; Declare the following results of each measure voted on at the election: Measure "F": (Mammoth Lakes Fire Protection District Special Tax) received a 65.4% number of yes votes rather than the required 66.6% (2/3) and therefore did not pass (received 1,293 yes votes but needed approximately 1,319); Pursuant to the Statement of Vote, the race for Supervisor, District 2 will have a run-off in the November 3, 2020 General Election between Rhonda Duggan and Joshua Rhodes.

**Fiscal Impact:** None.

### B. **COVID-19 (Coronavirus) Update**

Departments: CAO

20 minutes

(Steve Barwick, CAO) - An opportunity for Mono County Departments and stakeholders to share Coronavirus-related issues with the Board, to include, but not limited to, the Public Health Department and its efforts to provide guidance and mitigation measures to reduce the impact of COVID-19 in Mono County and the Eastern Sierra.

**Recommended Action:** None, informational only.

**Fiscal Impact:** None.

### C. **Budget Appropriation to Fund the County's Response to the COVID-19 (Coronavirus) Epidemic**

Departments: CAO, Finance, County Counsel

5 minutes

(Janet Dutcher) - On March 15, 2020, Mono County Public Health Officer declared a local health emergency because of the Coronavirus (COVID-19) and the Board of

Supervisors ratified that declaration by resolution on March 17, 2020. This item requests transfer of \$500,000 from the County's general reserve (as allowed by Government Code 29127(a)) into the County's Disaster Assistance Fund for the purpose of providing resources that pay for the cost of Mono County's response to this emergency. Estimate is based on available information at this time. Additional appropriations may be needed later on. Requires 4/5ths vote.

**Recommended Action:** Approve transfer of \$500,000 from the County's general reserve to support the County's response to the proclaimed COVID-19 emergency (requires 4/5ths vote).

**Fiscal Impact:** This action if approved provides up to \$500,000 in funding for Mono County's COVID-19 response and decreases the balance in the general reserve from \$3.2 million to \$2.7 million. Any funding not spent after the emergency ends can be transferred back into the County's general reserve.

**D. Use of Local Lodging Facilities for Emergency Operations and Response**

Departments: CAO

15 minutes

(Steve Barwick, Kathy Petersen) - Update from staff regarding the establishment of relationships with lodging operators to secure rooms for use in COVID-19 response including, but not limited to, housing healthcare and other essential infrastructure maintenance workers and/or to create locations for the isolation or quarantine of individuals who have been infected by or exposed to the virus. Update from staff regarding the establishment of relationships with willing lodging operators to secure rooms for use in COVID-19 response including, but not limited to, housing healthcare and other essential infrastructure maintenance workers and/or to create locations for the isolation or quarantine of individuals who have been infected by or exposed to the virus.

**Recommended Action:** Receive update and provide any desired direction to staff.

**Fiscal Impact:** Details regarding total cost, and the amount to be shared by partner agencies, including the Town of Mammoth Lakes, are currently being determined. Estimated cost of \$150,000-\$200,000, to be paid from fund 179 Disaster Assistance, assuming the general fund appropriation request today is approved.

**E. Board Advisory Committee for COVID-19 (Coronavirus)**

Departments: Board of Supervisors

5 minutes

The Brown Act allows for the establishment of temporary advisory committees comprised of less than a quorum of the membership of the Board (i.e., no more than two Board member) to focus on a particular issue or topic of within the jurisdiction of the Board or agency. (Gov. Code 54952(b).) These temporary advisory committees are sometimes referred to as "ad hoc committees". Ad hoc committees may meet, investigate, participate and engage in activities related to

the designated issue or topic, without such activity triggering the notice and agenda requirements of the Brown Act.

**Recommended Action:** Consider and potentially establish a temporary advisory committee to the Board related to the COVID-19 (Coronavirus) situation and Mono County response, for so long as COVID-19 response is required. Designate two Board members to act as that committee.

**Fiscal Impact:** None.

**F. Civic Center Update**

Departments: Public Works

20 minutes

(Tony Dublino, Director of Public Works; Nate Greenberg, IT Director) - Weekly update on the County's Civic Center project at 1290 Tavern Road, and efforts to transition from other Mammoth locations into the Civic Center as of June 1, 2020.

**Recommended Action:** None; Informational only.

**Fiscal Impact:** None.

**G. Bid Package and Invitation for Bids for the Mono County Civic Center Top Lift Asphalt Paving Project**

Departments: Public Works Department

30 minutes

(Tony Dublino, Garrett Higerd) - Approval of the Mono County Civic Center Top Lift Asphalt Paving Project and Authorization to Issue Invitation for Bids

**Recommended Action:** Approve bid package, including the project manual and project plans, for the Mono County Civic Center Top Lift Asphalt Paving Project. Authorize the Public Works Department to advertise an Invitation for Bids and to issue the project for bid. Provide any desired direction to staff.

**Fiscal Impact:** Until bids are received, the fiscal impact is unknown. There is approximately \$185,000 surplus available in the Mono County Civic Center Project (193-3250) budget that could be applied to this portion of the Project. Any additional amounts would require Board approval.

**H. Closed Session - Exposure to Litigation**

CONFERENCE WITH LEGAL COUNSEL – ANTICIPATED LITIGATION.  
Significant exposure to litigation pursuant to paragraph (2) of subdivision (d) of Government Code section 54956.9. Number of potential cases: two.

**I. Urgency Ordinance Adding Chapter 7.93 to the Mono County Code Temporarily Prohibiting Residential or Commercial Evictions**

Departments: County Counsel

15 minutes

(Stacey Simon, County Counsel) - The ordinance presented to your Board today adds Chapter 7.93 to the Mono County Code to temporarily prohibit (until May 31, 2020, unless extended) residential or commercial evictions arising from income loss or substantial medical expenses related to the COVID-19 pandemic. As drafted, Chapter 7.93 does not relieve a tenant from the obligation to pay rent or restrict a landlord's ability to recover rent that is due and requires tenants seeking protection under Chapter 7.93 to thoroughly document their hardship.

**Recommended Action:** Adopt proposed ordinance ORD20-\_\_\_, Adding Chapter 7.93 to the Mono County Code to prohibit residential or commercial evictions through May 31, 2020, arising from income loss or substantial medical expenses related to the corona virus pandemic.

**Fiscal Impact:** None.

**ADJOURN**



OFFICE OF THE CLERK  
OF THE BOARD OF SUPERVISORS

## SPECIAL MEETING AGENDA REQUEST

Print

<b>MEETING DATE</b>	March 26, 2020	<b>DEPARTMENT</b>	
<b>ADDITIONAL DEPARTMENTS</b>			
<b>TIME REQUIRED</b>	10 minutes (5 minute presentation; 5 minute discussion)	<b>PERSONS APPEARING BEFORE THE BOARD</b>	Shannon Kendall, Registrar of Voters
<b>SUBJECT</b>	Review and Declaration of Election Results		

### AGENDA DESCRIPTION:

(A brief general description of what the Board will hear, discuss, consider, or act upon)

Presentation of certified election results. Request for declaration of results. To view the complete Statement of Votes Cast (that will be submitted to the Secretary of State electronically), visit <https://monocounty.ca.gov/elections/page/march-3-2020-primary-election-results>

### RECOMMENDED ACTION:

Approve as correct the Statement of Votes for the March 3, 2020 Presidential Primary Election and Declare elected to office the following candidates who received the highest number of votes in each contest of the Election: Bob Gardner for Mono County Supervisor, District 3; John Peters for Mono County Supervisor, District 4; Declare the following results of each measure voted on at the election: Measure "F": (Mammoth Lakes Fire Protection District Special Tax) received a 65.4% number of yes votes rather than the required 66.6% (2/3) and therefore did not pass (received 1,293 yes votes but needed approximately 1,319); Pursuant to the Statement of Vote, the race for Supervisor, District 2 will have a run-off in the November 3, 2020 General Election between Rhonda Duggan and Joshua Rhodes.

### FISCAL IMPACT:

None.

**CONTACT NAME:** Shannon Kendall

**PHONE/EMAIL:** x5533 / skendall@mono.ca.gov

SUBMIT THE ORIGINAL DOCUMENT WITH  
ATTACHMENTS TO THE OFFICE OF  
THE COUNTY ADMINISTRATOR  
**PRIOR TO 5:00 P.M. ON THE FRIDAY**  
**32 DAYS PRECEDING THE BOARD MEETING**

**SEND COPIES TO:**

None.

### MINUTE ORDER REQUESTED:

YES  NO

### ATTACHMENTS:

<b>Click to download</b>
<a href="#">Staff Report</a>
<a href="#">Final Election Summary Report</a>
<a href="#">Back up Documents</a>

---

**History**

<b>Time</b>	<b>Who</b>	<b>Approval</b>
3/24/2020 2:38 PM	County Administrative Office	Yes
3/24/2020 9:33 AM	County Counsel	Yes
3/24/2020 4:25 PM	Finance	Yes



**CLERK – RECORDER – REGISTRAR  
COUNTY OF MONO**

---

P.O. BOX 237, BRIDGEPORT, CALIFORNIA 93517  
(760) 932-5530 • FAX (760) 932-5531

Shannon Kendall  
Clerk-Recorder-Registrar  
760-932-5533  
[skendall@mono.ca.gov](mailto:skendall@mono.ca.gov)

To: Honorable Board of Supervisors  
From: Shannon Kendall, Registrar of Voters  
Date: March 26, 2020

Subject

Certification and Declaration of the County Clerk/Registrar of Voters of the Results of the March 3, 2020 Presidential Primary Election.

Recommended Action

1. Approve as correct the Statement of Votes for the March 3, 2020 Presidential Primary Election and Declare elected to office the following candidates who received the highest number of votes in each contest of the Election:
  - a. Bob Gardner for Mono County Supervisor, District 3;
  - b. John Peters for Mono County Supervisor, District 4;
2. Declare the following results of each measure voted on at the election: Measure "F": (Mammoth Lakes Fire Protection District Special Tax) received a 65.4% number of yes votes rather than the required 66.6% (2/3) and therefore did not pass (received 1,293 yes votes but needed approximately 1,319);
3. Pursuant to the Statement of Vote, the race for Supervisor, District 2 will have a run-off in the November 3, 2020 General Election between Rhonda Duggan and Joshua Rhodes.

Discussion

On March 3, 2020, the Presidential Primary Election was held.

Per Elections Code §15372,

*The elections official shall prepare a certified statement of the results of the election and submit to the governing body within 30 days of the election.*

Per Elections Code §15400,

*The governing body shall declare elected or nominated to each office voted on at each election under its jurisdiction the person having the highest number of votes for that office, or who was elected or nominated under the exceptions noted in Section 15452. The governing board shall also declare the results of each election under its jurisdiction as to each measure voted on at the election.*



Following the canvass of the election, the results of each election contest are on the attached Certification of Vote.

Fiscal Impact

None.

# Election Summary Report

Closed Primary

Mono

March 03, 2020

Summary for: All Contests, All Precincts, All Tabulators, All Counting Groups

## FINAL COUNTYWIDE SUMMARY REPORT ALL PRECINCT, VOTE-BY-MAIL, PROVISIONAL AND CONDITIONAL BALLOTS COUNTED - 03/18/2020

Electors Group	Counting Group	Voters Cast	Registered Voters	Turnout
American Independent	Election Day	27	263	10.27%
	Vote by Mail	70		26.62%
	Provisional	2		0.76%
	Conditional	3		1.14%
	Total	102		38.78%
Democratic	Election Day	550	2,627	20.94%
	Vote by Mail	1,571		59.80%
	Provisional	134		5.10%
	Conditional	65		2.47%
	Total	2,320		88.31%
Green	Election Day	3	50	6.00%
	Vote by Mail	10		20.00%
	Provisional	0		0.00%
	Conditional	0		0.00%
	Total	13		26.00%
Libertarian	Election Day	9	79	11.39%
	Vote by Mail	17		21.52%
	Provisional	4		5.06%
	Conditional	2		2.53%
	Total	32		40.51%
Peace and Freedom	Election Day	0	29	0.00%
	Vote by Mail	4		13.79%
	Provisional	0		0.00%
	Conditional	0		0.00%
	Total	4		13.79%
Republican	Election Day	374	2,178	17.17%
	Vote by Mail	1,020		46.83%
	Provisional	41		1.88%
	Conditional	19		0.87%
	Total	1,454		66.76%
Non-Partisan (SystemUse)	Election Day	38	1,869	2.03%
	Vote by Mail	282		15.09%
	Provisional	19		1.02%
	Conditional	3		0.16%
	Total	342		18.30%
Total	Election Day	1,001		14.11%

Total	Vote by Mail	2,974	41.92%
	Provisional	200	2.82%
	Conditional	92	1.30%
	Total	4,267	60.14%
		7,095	

Precincts Reported: 12 of 12 (100.00%)

Voters Cast: 4,267 of 7,095 (60.14%)

## President of the US (Dem) (Vote for 1) DEM

Precincts Reported: 12 of 12 (100.00%)

	Total	
Times Cast	2,320 / 2,627	88.31%

Candidate	Party	Total
JULIÁN CASTRO	DEM	1
MICHAEL A. ELLINGER	DEM	0
ELIZABETH WARREN	DEM	301
MARIANNE WILLIAMSON	DEM	3
ANDREW YANG	DEM	9
ROQUE "ROCKY" DE LA FUENTE III	DEM	2
JOHN K. DELANEY	DEM	0
AMY KLOBUCHAR		100
BERNIE SANDERS	DEM	791
JOE SESTAK	DEM	1
TOM STEYER	DEM	59
DEVAL PATRICK	DEM	0
MICHAEL BENNET	DEM	2
MICHAEL R. BLOOMBERG	DEM	200
MOSIE BOYD	DEM	2
CORY BOOKER	DEM	3
PETE BUTTIGIEG	DEM	167
JOSEPH R. BIDEN	DEM	640
TULSI GABBARD	DEM	22
MARK STEWART GREENSTEIN	DEM	0
Total Votes		2,303

		Total
NAKIA L. ANTHONY	WRITE-IN	0
DAPHNE DENISE BRADFORD	WRITE-IN	0
WILLIE FELIX CARTER	WRITE-IN	0
MICHAEL DENAME	WRITE-IN	0
JEFFREY H. DROBMAN	WRITE-IN	0
ROBERT JORDAN	WRITE-IN	0
HEATHER MARIE STAGG	WRITE-IN	0

## President of the US (Rep) (Vote for 1) REP

Precincts Reported: 12 of 12 (100.00%)

	Total	
Times Cast	1,454 / 2,178	66.76%

Candidate	Party	Total	
ROBERT ARDINI	REP	4	
JOE WALSH	REP	35	
BILL WELD	REP	31	
ROQUE "ROCKY" DE LA FUENTE	REP	15	
MATTHEW JOHN MATERN	REP	15	
ZOLTAN G. ISTVAN	REP	8	
DONALD J. TRUMP	REP	1,268	
Total Votes		1,376	

		Total	
DENIS C. GRASSKA	WRITE-IN	0	
ROBERT LEE MANNING JR.	WRITE-IN	0	

## President of the US (AI) (Vote for 1) AI

Precincts Reported: 12 of 12 (100.00%)

	Total	
Times Cast	102 / 263	38.78%

Candidate	Party	Total	
PHIL COLLINS	AI	9	
ROQUE "ROCKY" DE LA FUENTE	AI	9	
CHARLES KRAUT	AI	4	
J. R. MYERS	AI	1	
DON BLANKENSHIP	AI	3	
Total Votes		26	

## President of the US (Green) (Vote for 1) GRN

Precincts Reported: 12 of 12 (100.00%)

	Total	
Times Cast	13 / 50	26.00%

Candidate	Party	Total	
DAVID ROLDE	GRN	2	
HOWIE HAWKINS	GRN	3	
DARIO HUNTER	GRN	1	
DENNIS LAMBERT	GRN	1	
SEDINAM MOYOWASIFZA-CURRY	GRN	1	
Total Votes		8	

		Total	
KENT MESPLAY	WRITE-IN	0	

## President of the US (Lib) (Vote for 1) LIB

Precincts Reported: 12 of 12 (100.00%)

	Total	
Times Cast	32 / 79	40.51%

Candidate	Party	Total	
KEN ARMSTRONG	LIB	0	
MAX ABRAMSON	LIB	0	
SAM ROBB	LIB	0	
KIM RUFF	LIB	0	
STEVEN A RICHEY	LIB	3	
JACOB HORNBERGER	LIB	6	
SOURAYA FAAS	LIB	2	
KEENAN WALLACE DUNHAM	LIB	0	
ADAM KOKESH	LIB	2	
VERMIN SUPREME	LIB	0	
JO JORGENSEN	LIB	1	
DAN BEHRMAN	LIB	1	
ERIK CHASE GERHARDT	LIB	1	
Total Votes		16	

		Total	
SORINNE ARDELEANU	WRITE-IN	0	
NICHOLAS D'ARTAGNAN DUMAS	WRITE-IN	0	
GEBY EVA ESPINOSA	WRITE-IN	0	
JAMES ORLANDO OGLE	WRITE-IN	0	

## President of the US (PF) (Vote for 1) PF

Precincts Reported: 12 of 12 (100.00%)

	Total	
Times Cast	4 / 29	13.79%

Candidate	Party	Total	
HOWIE HAWKINS	PF	2	
GLORIA LA RIVA	PF	0	
Total Votes		2	

## U.S. Representative (Vote for 1)

Precincts Reported: 12 of 12 (100.00%)

		Total	
Times Cast		4,267 / 7,095	60.14%
Candidate	Party	Total	
BOB CONAWAY	DEM	240	
JAMES ELLARS	DEM	186	
JEFF ESMUS		126	
JUSTIN DAVID WHITEHEAD	REP	57	
JERRY LAWS	REP	33	
JAY OBERNOLTE	REP	916	
TIM DONNELLY	REP	572	
JEREMY STAAT	REP	57	
CHRISTINE BUBSER	DEM	1,877	
Total Votes		4,065	
		Total	
J. GREEN	WRITE-IN	1	

## Member State Assembly (Vote for 1)

Precincts Reported: 12 of 12 (100.00%)

		Total	
Times Cast		4,267 / 7,095	60.14%
Candidate	Party	Total	
FRANK BIGELOW	REP	2,138	
Total Votes		2,138	

## Supervisor 2nd Dist (Vote for 1)

Precincts Reported: 3 of 3 (100.00%)

		Total	
Times Cast		1,227 / 1,782	68.86%
Candidate	Party	Total	
JOSHUA G. RHODES		489	
RHONDA DUGGAN		563	
Total Votes		1,165	
		Total	
ERIC OLSON	WRITE-IN	113	

## Supervisor 3rd Dist (Vote for 1)

Precincts Reported: 3 of 3 (100.00%)

	Total	
Times Cast	932 / 1,622	57.46%

Candidate	Party	Total
BOB GARDNER		618
Total Votes		618

## Supervisor 4th Dist (Vote for 1)

Precincts Reported: 3 of 3 (100.00%)

	Total	
Times Cast	900 / 1,454	61.90%

Candidate	Party	Total
JOHN PETERS		661
Total Votes		661

## Proposition 13 (Vote for 1)

Precincts Reported: 12 of 12 (100.00%)

	Total	
Times Cast	4,267 / 7,095	60.14%

Candidate	Party	Total
Yes		1,641
No		2,484
Total Votes		4,125

## Measure F (Vote for 1)

Precincts Reported: 5 of 5 (100.00%)

	Total	
Times Cast	2,025 / 3,669	55.19%

Candidate	Party	Total
Yes		1,293
No		685
Total Votes		1,978

**CERTIFICATION OF  
COUNTY CLERK/REGISTRAR OF VOTERS OF THE  
RESULTS OF THE CANVASS  
OF THE MARCH 3, 2020,  
PRESIDENTIAL PRIMARY ELECTION**

STATE OF CALIFORNIA

COUNTY OF Mono



ss.

I, Shannon Kendall, County Clerk/Registrar of Voters of County  
of Mono, do hereby certify that, in pursuance of the provisions of Elections Code  
section 15300, et seq., I did canvass the results of the votes cast in the Presidential Primary Election  
held in said County on March 3, 2020, for measures and contests that were submitted to the vote of the  
voters, and that the Statement of Votes Cast, to which this certificate is attached is full, true, and correct.

I hereby set my hand and official seal this 25th day of March, 2020, at the  
County of Mono



Shannon Kendall

County Clerk/Registrar of Voters

County of Mono

State of California

Canvass Certification of Elections Official  
(03/2020)



**HELP AMERICA VOTE ACT OF 2002  
CERTIFICATION OF ELECTIONS OFFICIAL**

STATE OF CALIFORNIA

COUNTY OF Mono

} SS.

Pursuant to the statewide voter registration list requirements set forth in the Help America Vote Act of 2002 (HAVA) 52 U.S.C. § 21083),

I, Shannon Kendall, County Clerk/Registrar of Voters for the County of Mono, State of California, hereby certify that I complied with all provisions of Chapter 2 of Division 7 of Title 2 of the California Code of Regulations for the Federal election held on the 3<sup>rd</sup> day of March 2020, in the County of Mono, State of California and all elections consolidated therewith.

I hereby set my hand and official seal this 25th day of March, 2020, at the County of Mono



Shannon Kendall

County Clerk/Registrar of Voters  
County of Mono  
State of California

HAVA Certification of Elections Official  
(03/2020)



**CLERK – RECORDER – REGISTRAR  
COUNTY OF MONO**

---

**P.O. BOX 237, BRIDGEPORT, CALIFORNIA 93517  
(760) 932-5530 • FAX (760) 932-5531**

Shannon Kendall  
Clerk-Recorder-Registrar  
760-932-5533  
[skendall@mono.ca.gov](mailto:skendall@mono.ca.gov)

Helen Nunn  
Asst. Clerk-Recorder-Registrar  
760-932-5534  
[hunn@mono.ca.gov](mailto:hunn@mono.ca.gov)

March 25, 2020

**1% Manual Tally Report**

In accordance with Section 15360 of the California Elections Code, Mono County conducted a manual tally of precincts totaling at least 1% of the votes cast in the March 3, 2020 Presidential Primary Election. The precinct randomly selected was Precinct 5 (June Lake). Additionally, Precincts 8 (Mammoth Meadow), and 11 (Swall Meadows, all mail ballot) were tallied for the results not included on June Lake's ballot which were the Mammoth Lakes Fire Protection District Measure "F", Supervisor for District 3 and Supervisor for District 4.

Participating in the tally were Shannon Kendall, Registrar of Voters and Helen Nunn, Assistant Registrar of Voters, Ashley Strain, Deputy Clerk from the Office of the Registrar of Voters. Also assisting with the tally was Renn Nolan, one of our temporary Election Assistant's.

All contests on the Precinct 5 ballot were hand tallied, as was the applicable races on Precinct 8 and 11 ballots. We hand tallied Precinct, Vote-by-Mail, Provisional and Conditional ballots pulled from "batches" of images on our database.

No discrepancies were discovered between the Election Night results and the manual hand tally on ANY of the races/measures tallied.

---

Shannon Kendall, Registrar of Voters

County Voting System Incident Report  
March 3, 2020, Presidential Primary Election

County Name Mono  
Contact Name Shannon Kendall Contact Phone (760) 932-5533

County **did not** have vote reporting incidents related to the March 3, 2020, Presidential Primary Election.

Date March 19, 2020

County Clerk/Registrar of Voters Shannon Kendall

County of Mono

-OR-

County had vote reporting incidents related to the March 3, 2020, Presidential Primary Election.

Date \_\_\_\_\_

County Clerk/Registrar of Voters \_\_\_\_\_

County of \_\_\_\_\_

You may use the attached Voting System Incident Report Template – 2020 Presidential Primary (Excel Workbook) to report these incidents.

Please return this document with your Official Canvass and Statement of Vote **no later than April 3, 2020** to:

Kirsten Larsen  
Secretary of State, Elections Division  
1500 11<sup>th</sup> Street, Fifth Floor  
Sacramento, CA 95814  
PHONE: (916) 653-9154  
FAX: (916) 651-6460  
[post-electionreporting@sos.ca.gov](mailto:post-electionreporting@sos.ca.gov)

If you have any questions, please call Kirsten at the number listed above. Thank you.



OFFICE OF THE CLERK  
OF THE BOARD OF SUPERVISORS

## SPECIAL MEETING AGENDA REQUEST

Print

<b>MEETING DATE</b>	March 26, 2020	<b>DEPARTMENT</b>	
<b>ADDITIONAL DEPARTMENTS</b>			
<b>TIME REQUIRED</b>	20 minutes	<b>PERSONS APPEARING BEFORE THE BOARD</b>	Steve Barwick, CAO
<b>SUBJECT</b>	COVID-19 (Coronavirus) Update		

### AGENDA DESCRIPTION:

(A brief general description of what the Board will hear, discuss, consider, or act upon)

An opportunity for Mono County Departments and stakeholders to share Coronavirus-related issues with the Board, to include, but not limited to, the Public Health Department and its efforts to provide guidance and mitigation measures to reduce the impact of COVID-19 in Mono County and the Eastern Sierra.

### RECOMMENDED ACTION:

None, informational only.

### FISCAL IMPACT:

None.

**CONTACT NAME:** Scheereen Dedman

**PHONE/EMAIL:** 7609325538 / sdedman@mono.ca.gov

SUBMIT THE ORIGINAL DOCUMENT WITH  
ATTACHMENTS TO THE OFFICE OF  
THE COUNTY ADMINISTRATOR  
**PRIOR TO 5:00 P.M. ON THE FRIDAY**  
**32 DAYS PRECEDING THE BOARD MEETING**

### SEND COPIES TO:

### MINUTE ORDER REQUESTED:

YES  NO

### ATTACHMENTS:

[Click to download](#)

No Attachments Available

History

<b>Time</b>	<b>Who</b>	<b>Approval</b>
3/24/2020 2:38 PM	County Administrative Office	Yes
3/23/2020 1:50 PM	County Counsel	Yes
3/24/2020 4:27 PM	Finance	Yes



OFFICE OF THE CLERK  
OF THE BOARD OF SUPERVISORS

## SPECIAL MEETING AGENDA REQUEST

Print

<b>MEETING DATE</b>	March 26, 2020	<b>DEPARTMENT</b>	
<b>ADDITIONAL DEPARTMENTS</b>			
<b>TIME REQUIRED</b>	5 minutes	<b>PERSONS APPEARING BEFORE THE BOARD</b>	Janet Dutcher
<b>SUBJECT</b>	Budget Appropriation to Fund the County's Response to the COVID-19 (Coronavirus) Epidemic		

### AGENDA DESCRIPTION:

(A brief general description of what the Board will hear, discuss, consider, or act upon)

On March 15, 2020, Mono County Public Health Officer declared a local health emergency because of the Coronavirus (COVID-19) and the Board of Supervisors ratified that declaration by resolution on March 17, 2020. This item requests transfer of \$500,000 from the County's general reserve (as allowed by Government Code 29127(a)) into the County's Disaster Assistance Fund for the purpose of providing resources that pay for the cost of Mono County's response to this emergency. Estimate is based on available information at this time. Additional appropriations may be needed later on.  
Requires 4/5ths vote.

### RECOMMENDED ACTION:

Approve transfer of \$500,000 from the County's general reserve to support the County's response to the proclaimed COVID-19 emergency (requires 4/5ths vote).

### FISCAL IMPACT:

This action if approved provides up to \$500,000 in funding for Mono County's COVID-19 response and decreases the balance in the general reserve from \$3.2 million to \$2.7 million. Any funding not spent after the emergency ends can be transferred back into the County's general reserve.

**CONTACT NAME:** Janet Dutcher

**PHONE/EMAIL:** 760-932-5494 / jdutcher@mono.ca.gov

SUBMIT THE ORIGINAL DOCUMENT WITH  
ATTACHMENTS TO THE OFFICE OF  
THE COUNTY ADMINISTRATOR  
**PRIOR TO 5:00 P.M. ON THE FRIDAY**  
**32 DAYS PRECEDING THE BOARD MEETING**

**SEND COPIES TO:**

### MINUTE ORDER REQUESTED:

YES  NO

### ATTACHMENTS:

Click to download

[Staff report](#)

---

### History

Time	Who	Approval
3/23/2020 1:39 PM	County Administrative Office	Yes
3/23/2020 3:23 PM	County Counsel	Yes
3/24/2020 4:27 PM	Finance	Yes



# DEPARTMENT OF FINANCE

## AUDITOR-CONTROLLER

### COUNTY OF MONO

---

*Kim Bunn*  
Assistant Finance Director  
Auditor-Controller

*Janet Dutcher, CPA, CGFM, MPA*  
Director of Finance

*P.O. Box 556*  
*Bridgeport, California 93517*  
*(760) 932-5490*  
*Fax (760) 932-5491*

**TO:** Honorable Board of Supervisors

**FROM:** Janet Dutcher, Finance  
Steve Barwick, CAO  
Stacey Simon, County Counsel

**DATE:** March 26, 2020

**RE:** Budget Appropriation – COVID-19 Response

**Recommended Action:**

Approve transfer of \$500,000 from the County's general reserve to support the County's response to the proclaimed COVID-19 emergency (requires 4/5ths vote).

**Discussion:**

On March 4, 2020, Governor Newsom declared a state of emergency for California in response to the coronavirus outbreak.

On March 15, 2020, the Mono County Health Officer declared a local health emergency due to the imminent and proximate threat to public health from the introduction of a novel coronavirus (COVID-19) in Mono County. Following this on March 17, 2020, your Board adopted a resolution ratifying the declaration of the local health emergency made by our health officer. On the evening of March 15, 2020, a joint Emergency Operations Center (EOC) was opened by Mono County and the Town of Mammoth Lakes to manage the COVID-19 incident.

Currently, County resources are being redirected towards responding to contain this new virus. Staff and benefit costs associated with redirecting non-Departmental Emergency personnel to support this declared emergency are being incurred. This is staff time that otherwise would have been spent on county activities and services often paid for with grant related funding sources which now may not be realized. County leaders expect incurring unanticipated expenditures during the course of this event, such as additional outside contracting, medical supplies, personal protective equipment, triage/surge centers, temporary housing, laptops for increased remote work capabilities, additional cleaning and sanitization of county facilities, and general costs of operating the EOC.



While the County does expect some level of reimbursement from Federal and State resources which is not available currently, there is an immediate need to appropriate local funding sources to pay for the County's emergency related expenditures. At this time, staff estimate \$500,000 is needed immediately.

The County's general reserve has a projected balance of \$3.2 million. The County Budget Act provides that the general reserve balance can be spent after the adoption of the budget only if there is a resolution in place that states the facts of an emergency. That resolution was adopted unanimously by your Board on March 17<sup>th</sup>. In Government Code section 29127(a), "epidemic" is listed as an allowed emergency use.

This action requests transfer of \$500,000 from the County's general reserve account into the Disaster Assistance Fund and appropriates \$500,000 of spending towards the County's response to the COVID-19 emergency.

**Fiscal Impact:**

This action, if approved, provides up to \$500,000 in funding for Mono County's coronavirus response and decreases the balance in the general reserve from \$3.2 million to \$2.7 million. Any funding not spent after the emergency ends, net of reimbursements from Federal and State sources, can be transferred back into the County's general reserve account.



**OFFICE OF THE CLERK  
OF THE BOARD OF SUPERVISORS**

**SPECIAL MEETING AGENDA REQUEST**

Print

<b>MEETING DATE</b>	March 26, 2020	<b>DEPARTMENT</b>	
<b>ADDITIONAL DEPARTMENTS</b>			
<b>TIME REQUIRED</b>	15 minutes	<b>PERSONS APPEARING BEFORE THE BOARD</b>	Steve Barwick, Kathy Petersen
<b>SUBJECT</b>	Use of Local Lodging Facilities for Emergency Operations and Response		

**AGENDA DESCRIPTION:**

(A brief general description of what the Board will hear, discuss, consider, or act upon)

Update from staff regarding the establishment of relationships with lodging operators to secure rooms for use in COVID-19 response including, but not limited to, housing healthcare and other essential infrastructure maintenance workers and/or to create locations for the isolation or quarantine of individuals who have been infected by or exposed to the virus. Update from staff regarding the establishment of relationships with willing lodging operators to secure rooms for use in COVID-19 response including, but not limited to, housing healthcare and other essential infrastructure maintenance workers and/or to create locations for the isolation or quarantine of individuals who have been infected by or exposed to the virus.

**RECOMMENDED ACTION:**

Receive update and provide any desired direction to staff.

**FISCAL IMPACT:**

Details regarding total cost, and the amount to be shared by partner agencies, including the Town of Mammoth Lakes, are currently being determined. Estimated cost of \$150,000-\$200,000, to be paid from fund 179 Disaster Assistance, assuming the general fund appropriation request today is approved.

**CONTACT NAME:** Steve Barwick

**PHONE/EMAIL:** x5414 / sbarwick@mono.ca.gov

SUBMIT THE ORIGINAL DOCUMENT WITH ATTACHMENTS TO THE OFFICE OF THE COUNTY ADMINISTRATOR  
**PRIOR TO 5:00 P.M. ON THE FRIDAY  
32 DAYS PRECEDING THE BOARD MEETING**

**SEND COPIES TO:**

**MINUTE ORDER REQUESTED:**

YES  NO

**ATTACHMENTS:**

---

**Click to download**

No Attachments Available

---

**History**

<b>Time</b>	<b>Who</b>	<b>Approval</b>
3/24/2020 3:14 PM	County Administrative Office	Yes
3/24/2020 1:52 PM	County Counsel	Yes
3/24/2020 4:30 PM	Finance	Yes



OFFICE OF THE CLERK  
OF THE BOARD OF SUPERVISORS

## SPECIAL MEETING AGENDA REQUEST

Print

<b>MEETING DATE</b>	March 26, 2020	<b>DEPARTMENT</b>	
<b>ADDITIONAL DEPARTMENTS</b>			
<b>TIME REQUIRED</b>	5 minutes	<b>PERSONS APPEARING BEFORE THE BOARD</b>	
<b>SUBJECT</b>	Board Advisory Committee for COVID-19 (Coronavirus)		

### AGENDA DESCRIPTION:

(A brief general description of what the Board will hear, discuss, consider, or act upon)

The Brown Act allows for the establishment of temporary advisory committees comprised of less than a quorum of the membership of the Board (i.e., no more than two Board member) to focus on a particular issue or topic of within the jurisdiction of the Board or agency. (Gov. Code 54952(b).) These temporary advisory committees are sometimes referred to as "ad hoc committees". Ad hoc committees may meet, investigate, participate and engage in activities related to the designated issue or topic, without such activity triggering the notice and agenda requirements of the Brown Act.

### RECOMMENDED ACTION:

Consider and potentially establish a temporary advisory committee to the Board related to the COVID-19 (Coronavirus) situation and Mono County response, for so long as COVID-19 response is required. Designate two Board members to act as that committee.

### FISCAL IMPACT:

None.

**CONTACT NAME:** Scheereen Dedman

**PHONE/EMAIL:** x5538 / sdedman@mono.ca.gov

SUBMIT THE ORIGINAL DOCUMENT WITH ATTACHMENTS TO THE OFFICE OF THE COUNTY ADMINISTRATOR  
**PRIOR TO 5:00 P.M. ON THE FRIDAY**  
**32 DAYS PRECEDING THE BOARD MEETING**

### SEND COPIES TO:

### MINUTE ORDER REQUESTED:

YES  NO

### ATTACHMENTS:

[Click to download](#)

**History**

<b>Time</b>	<b>Who</b>	<b>Approval</b>
3/24/2020 3:14 PM	County Administrative Office	Yes
3/24/2020 10:50 AM	County Counsel	Yes
3/24/2020 4:27 PM	Finance	Yes



**OFFICE OF THE CLERK  
OF THE BOARD OF SUPERVISORS**

**SPECIAL MEETING AGENDA REQUEST**

Print

<b>MEETING DATE</b>	March 26, 2020	<b>DEPARTMENT</b>	
<b>ADDITIONAL DEPARTMENTS</b>			
<b>TIME REQUIRED</b>	20 minutes	<b>PERSONS APPEARING BEFORE THE BOARD</b>	Tony Dublino, Director of Public Works; Nate Greenberg, IT Director
<b>SUBJECT</b>	Civic Center Update		

**AGENDA DESCRIPTION:**

(A brief general description of what the Board will hear, discuss, consider, or act upon)

Weekly update on the County's Civic Center project at 1290 Tavern Road, and efforts to transition from other Mammoth locations into the Civic Center as of June 1, 2020.

**RECOMMENDED ACTION:**

None; Informational only.

**FISCAL IMPACT:**

None.

**CONTACT NAME:** Tony Dublino

**PHONE/EMAIL:** 760.932.5459 / tdublino@mono.ca.gov

SUBMIT THE ORIGINAL DOCUMENT WITH ATTACHMENTS TO THE OFFICE OF THE COUNTY ADMINISTRATOR  
**PRIOR TO 5:00 P.M. ON THE FRIDAY  
32 DAYS PRECEDING THE BOARD MEETING**

**SEND COPIES TO:**

**MINUTE ORDER REQUESTED:**

YES  NO

**ATTACHMENTS:**

<a href="#">Click to download</a>
No Attachments Available

**History**

Time

Who

Approval

3/23/2020 1:39 PM	County Administrative Office	Yes
3/23/2020 1:34 PM	County Counsel	Yes
3/24/2020 4:28 PM	Finance	Yes



**OFFICE OF THE CLERK  
OF THE BOARD OF SUPERVISORS**

**SPECIAL MEETING AGENDA REQUEST**

Print

<b>MEETING DATE</b>	March 26, 2020	<b>DEPARTMENT</b>	
<b>ADDITIONAL DEPARTMENTS</b>			
<b>TIME REQUIRED</b>	30 minutes	<b>PERSONS APPEARING BEFORE THE BOARD</b>	Tony Dublino, Garrett Higerd
<b>SUBJECT</b>	Bid Package and Invitation for Bids for the Mono County Civic Center Top Lift Asphalt Paving Project		

**AGENDA DESCRIPTION:**

(A brief general description of what the Board will hear, discuss, consider, or act upon)

Approval of the Mono County Civic Center Top Lift Asphalt Paving Project and Authorization to Issue Invitation for Bids

**RECOMMENDED ACTION:**

Approve bid package, including the project manual and project plans, for the Mono County Civic Center Top Lift Asphalt Paving Project. Authorize the Public Works Department to advertise an Invitation for Bids and to issue the project for bid. Provide any desired direction to staff.

**FISCAL IMPACT:**

Until bids are received, the fiscal impact is unknown. There is approximately \$185,000 surplus available in the Mono County Civic Center Project (193-3250) budget that could be applied to this portion of the Project. Any additional amounts would require Board approval.

**CONTACT NAME:** Tony Dublino

**PHONE/EMAIL:** (760) 932-5459 / tdublino@mono.ca.gov

SUBMIT THE ORIGINAL DOCUMENT WITH ATTACHMENTS TO THE OFFICE OF THE COUNTY ADMINISTRATOR  
**PRIOR TO 5:00 P.M. ON THE FRIDAY  
32 DAYS PRECEDING THE BOARD MEETING**

**SEND COPIES TO:**

**MINUTE ORDER REQUESTED:**

YES  NO

**ATTACHMENTS:**

Click to download
<a href="#">Staff Report</a>
<a href="#">Bid Package</a>



---

**History**

<b>Time</b>	<b>Who</b>	<b>Approval</b>
3/24/2020 6:37 PM	County Administrative Office	Yes
3/24/2020 4:41 PM	County Counsel	Yes
3/24/2020 4:33 PM	Finance	Yes



# MONO COUNTY

## DEPARTMENT OF PUBLIC WORKS

---

POST OFFICE BOX 457 • 74 NORTH SCHOOL STREET • BRIDGEPORT, CALIFORNIA 93517  
760.932.5440 • Fax 760.932.5441 • [monopw@mono.ca.gov](mailto:monopw@mono.ca.gov) • [www.monocounty.ca.gov](http://www.monocounty.ca.gov)

**Date:** March 26, 2020

**To:** Honorable Chair and Members of the Board of Supervisors

**From:** Garrett Higerd, County Engineer

**Re:** Mono County Civic Center Top Lift Asphalt Paving – Approval to Bid

### **Recommended Action:**

Approve bid package, including the project manual and project plans, for the Mono County Civic Center Top Lift Asphalt Paving Project. Authorize the Public Works Department to advertise an Invitation for Bids and to issue the project for bid. Provide any desired direction to staff.

### **Fiscal Impact:**

Until bids are received, the fiscal impact is unknown. There is approximately \$185,000 surplus available in the Civic Center (193-3250) budget that could be applied to this portion of the project. Any additional amounts would require Board approval.

A project bid alternate is included that would add a 5-foot wide asphalt sidewalk on Tavern Road from the Civic Center to Sierra Park Road. Exact amounts will be based on actual bids received.

### **Background:**

The Civic Center Design-Build Request for Proposals originally specified a 3-inch thick asphalt paving section. However, during the Schematic Design process, it was determined that because the parking lot is a continuation of Tavern Road and Thompsons Way, and would be accepted into the Town of Mammoth Lakes road system, the structural section must be a minimum of 4-inches.

Last November, Roebbelen Construction's sub-contractor placed the base layer of asphalt just in time to prepare the site for winter. The work did not include the additional 1" of asphalt that was added to meet Town Road standards.

As such, the County is interested in obtaining separate proposals to cover this additional depth of asphalt and to complete the access and parking lot. The project manual (contract documents, special provisions, technical specifications, etc.) and plans are attached to this staff report for Board reference.

Approval of the bid documents at this meeting will allow advertising to take place and completion of the project prior to the scheduled June 1, 2020 building occupancy. A mitigated Negative Declaration was prepared for this project in compliance with the California Environmental Quality Act (CEQA).

Please contact me at 760.924.1802 or by email at [ghigerd@mono.ca.gov](mailto:ghigerd@mono.ca.gov) if you have any questions regarding this matter.

Respectfully submitted,



---

Garrett Higerd  
County Engineer

Attachments: Project Manual  
Project Plans

**PROJECT MANUAL**  
**FOR**  
**MONO COUNTY CIVIC CENTER**  
**TOP LIFT ASPHALT PAVING PROJECT**  
**Project No. MCCC PAVING**  
**MONO COUNTY, CALIFORNIA**



***Invitation for Bids***  
***Instructions to Bidders***  
***Proposal Forms***  
***Sample Standard Agreement***  
***Technical Specifications & Construction Quality Assurance Program***  
***Project Plans***

CONTRACTING AGENCY:  
COUNTY OF MONO

Department of Public Works  
Post Office Box 457  
74 North School Street  
Bridgeport, California 93517  
760.932.5440

**March 2020**

**OPTIONAL PRE-BID CONFERENCE:**

**11:00 am, Wednesday April 8, 2020**  
Mono County Civic Center  
1290 Tavern Road  
Mammoth Lakes, California 93546  
(760) 709-2354

**BID SUBMITTAL DEADLINE:**

**3:00 pm, Monday April 13, 2020**  
Clerk of the Board of Supervisors  
74 North School Street / P.O. Box 237  
Bridgeport, California 93517

This page intentionally left blank

# **CERTIFICATION PAGE**

County of Mono, Department of Public Works

**Mono County Civic Center  
Top Lift Asphalt Paving  
Project No. MCCC PAVING**

These contract documents, plans, specifications and special provisions contained herein have been prepared by, or under the direction of, the following registered civil engineer:



**APPROVED BY:**

(Signature)

March 26, 2020

Date

Garrett Ralph Higerd  
C70926, Expiration: 06/30/2021  
County Engineer  
County of Mono Department of Public Works  
74 North School Street  
Bridgeport, California 93517

This page intentionally left blank

# **TABLE OF CONTENTS**

*Mono County Civic Center  
Top Lift Asphalt Paving  
Project No. MCCC PAVING*

## SECTION I

INVITATION FOR BIDS .....	IB-1
INSTRUCTIONS TO BIDDERS .....	IB-3
PROPOSAL FORMS	
PROPOSAL .....	BD-1
BID SCHEDULE .....	BD-3
ACKNOWLEDGEMENTS .....	BD-5
LIST OF SUBCONTRACTORS.....	BD-6
DISCLOSURES AND CERTIFICATIONS .....	BD-8
BIDDER'S QUALIFICATION STATEMENT .....	BD-12
BID BOND .....	BD-18

## SECTION II

SAMPLE STANDARD AGREEMENT .....	SA-1
ATTACHMENT A .....	SA-9
ATTACHMENT B .....	SA-11
EXHIBIT 1 GENERAL CONDITIONS .....	SA-13
EXHIBIT 2 PREVAILING WAGES .....	SA-33
EXHIBIT 3 BOND REQUIREMENTS .....	SA-41
EXHIBIT 4 INVOICING, PAYMENT, AND RETENTION .....	SA-49

## SECTION III

TECHNICAL SPECIFICATIONS .....	TS-1
CONSTRUCTION QUALITY ASSURANCE PROGRAM .....	QA-1

## SECTION IV

PROJECT PLANS .....	T1
---------------------	----



This page intentionally left blank

# SECTION I



## INVITATION FOR BIDS

**Mono County Civic Center  
Top Lift Asphalt Paving Project**

**Project No. MCCC PAVING**

This page intentionally left blank

COUNTY OF MONO  
DEPARTMENT OF PUBLIC WORKS  
**INVITATION FOR BIDS**  
MONO COUNTY CIVIC CENTER  
TOP LIFT ASPHALT PAVING PROJECT  
Project No. MCCC PAVING

Notice is hereby given that the Mono County ("County") Department of Public Works calls for bids from qualified General Engineering and Asphalt Paving contractors for the **MONO COUNTY CIVIC CENTER TOP LIFT ASPHALT PAVING PROJECT** ("Project"). The purpose of this Project is to place asphalt serving the new Mono County Civic Center in Mammoth Lakes including: a top lift of asphalt on portions of Tavern Road and Thompsons Way; a parking area on the northwest of the building; and, potentially, a sidewalk along Tavern Road.

No contractor or subcontractor may be listed in a bid proposal or awarded a contract for this project unless registered with the Department of Industrial Relations pursuant to Labor Code section 1725.5 (unless one of the limited time extensions set forth in Labor Code section 1771.1 applies, in which case registration must be completed by the time of contract award). This Project is subject to compliance monitoring and enforcement by the Department of Industrial Relations.

The Project Manual and Project Plans provide, in detail, the requirements for the Project. The Project Manual, Project Plans, and related Project documents are available on the Mono County Bid Management System. To access the system, go to <http://bids.monocounty.ca.gov/> and click on "view details" to the right of the name of this Project in the RFP/RFQ/RFB Title list. This page shows the Project summary, status, bid due date, up-to-date plan-holders list, and supporting documents. If you would like to be added to the plan-holder list and receive email notices when addenda are posted, click "Click here to create a new user account." After registering your company, click "Add me to the Plan-holder List." You can ask questions about the project by clicking "Ask a question about this solicitation." If you would like assistance registering and using the Bid Management System, please contact us at 760.932.5440 or [publicworks@mono.ca.gov](mailto:publicworks@mono.ca.gov).

Each bid shall be made on the proposal forms contained in the Project Manual and must be accompanied by bid security in the amount of not less than 10 percent (10%) of the total bid.

In accordance with Public Contract Code section 22038, the County has the option, after receiving and tabulating bids, to reject all bids and perform the work by force account if the Board of Supervisors determines, by a four-fifths vote, that the work can be performed more economically by its own employees.

The Project and all work must be completed by **May 15, 2020**.

An **optional** pre-bid conference and **mandatory** site visit will be held at the Mono County Civic Center project site, 1290 Tavern Road, Mammoth Lakes, California 93546. The meeting is scheduled for **11:00 am Wednesday April 8, 2020**. Please note that the site visit is mandatory for each bidder to be considered responsive. In this case, a site visit is necessary to ensure interested bidders not only understand the specifics of the Mono County Civic Center site but also to appreciate the coordination necessary to allow the County's design-builder and its

subcontractors to timely complete construction of the Mono County Civic Center. Should the Department of Public Works determine there is a need to reschedule the pre-bid conference based on severe weather and/or road conditions, all plan-holders will be notified in advance.

NOTE: Due to the coronavirus (COVID-19) emergency, interested bidders may participate in the optional pre-bid conference via teleconference by using the following telephone number: 760-709-2354. However, during the mandatory site visit, the Department of Public Works will require that interested bidders attending the mandatory site visit maintain a minimum of six-feet of social distancing.

Bids may be mailed to the Clerk of the Board of Supervisors, P.O. Box 237, Bridgeport, California, 93517, or delivered to the office of the Clerk of the Board of Supervisors, 74 North School Street, Bridgeport, California. In either event, to be considered, bids must be **received** by the Clerk of the Board of Supervisors no later than **3:00 pm Monday April 13, 2020 (“Bid Submission Deadline”)**.

As soon thereafter as is practicable, all bids received by the Clerk as of the Bid Submission Deadline will be taken to the Department of Public Works Conference Room, located on the second floor of Courthouse Annex 1, 74 North School Street, Bridgeport, California 93517, and there publicly opened, read aloud, and recorded. All interested parties are invited to attend.



Garrett Higerd  
County Engineer  
Mono County Department of Public Works

COUNTY OF MONO, DEPARTMENT OF  
PUBLIC WORKS**INSTRUCTIONS TO BIDDERS**MONO COUNTY CIVIC CENTER  
TOP LIFT ASPHALT PAVING PROJECT  
Project No. MCCC PAVING**1. SECURING BID DOCUMENTS**

The Project Manual, which includes the Invitation for Bids, Instructions to Bidders, Proposal Forms, Sample Standard Agreement, Technical Specifications, Construction Quality Assurance Program, and Project Plans provide in detail the requirements for the Project. The Project Manual is available on the Mono County Bid Management System. To access the system go to <http://bids.monocounty.ca.gov/> and click on “view details” to the right of the name of the Project in the RFP/RFQ/RFB Title list. This page shows the Project summary, status, bid due date, up-to-date plan-holders list, and supporting documents. If you would like to be added to the plan-holder list and receive email notices when addenda are posted, click “Click here to create a new user account.” After registering your company, click “Add me to the Plan-holder List.” You can ask questions about the Project by clicking “Ask a question about this solicitation.” If you would like assistance registering and using the Bid Management System, please contact us at 760.932.5440 or [publicworks@mono.ca.gov](mailto:publicworks@mono.ca.gov).

**2. PRE-BID CONFERENCE**

An **optional** pre-bid conference and **mandatory** site visit will be held at the Mono County Civic Center project site, 1290 Tavern Road, Mammoth Lakes, California 93546. The meeting is scheduled for **11:00 am Wednesday April 8, 2020**. Please note that the site visit is mandatory for each bidder to be considered responsive. In this case, a site visit is necessary to ensure interested bidders not only understand the specifics of the Mono County Civic Center site but also to appreciate the coordination necessary to allow the County’s design-builder and its subcontractors to timely complete construction of the Mono County Civic Center. Should the Department of Public Works determine there is a need to reschedule the pre-bid conference based on severe weather and/or road conditions, all plan-holders will be notified in advance.

NOTE: Due to the coronavirus (COVID-19) emergency, interested bidders may participate in the optional pre-bid conference via teleconference by using the following telephone number: 760-709-2354. However, during the mandatory site visit, the Department of Public Works will require that interested bidders attending the mandatory site visit maintain a minimum of six-feet of social distancing.

**3. INTERPRETATION OF PROJECT PLANS AND SPECIFICATIONS**

- A. For information not provided in the Project Manual, bidders shall refer to the Standard Plans or Standard Specifications.
- B. Should bidders find discrepancies in, ambiguities, or omissions from, the Project Manual, or should there be any doubt as to their meaning, they shall at once notify the Director of the Department of Public Works and, should it be found necessary, a written addendum or bulletin of instructions will be sent to all plan-holders and posted on the Mono County Bid Management System. Failure to raise any such concerns prior to the submission of a bid will be deemed to waive such issues following the award of a contract. In the event that written addenda or bulletins of instructions are issued, all bidders will be required to

acknowledge that they have reviewed and considered such addenda or bulletins in formulating their bids.

- C. No employee, agent, or representative of the County, or anyone else, is authorized to give oral instructions, interpretations, or explanations of the Project Manual, and a submission of a bid constitutes agreement by a bidder that its representative has placed no reliance on any such oral explanation or interpretation. Oral instructions may, however, be given by the County or its agent upon inquiry by a bidder to direct the bidder's attention to the specific provisions of the Project Manual that cover the subject of the inquiry.

#### 4. APPROXIMATE QUANTITIES

The quantities given in the Bid Schedule are approximate only and are being given as a basis for the comparison of bids. The County does not, expressly or by implication, agree that the actual amount of work will correspond therewith, and the County reserves the right to increase or decrease the amount of any class or portion of the work, or to omit portions of the work, as may be deemed necessary.

#### 5. PROPOSALS

- A. For bids to receive consideration, they shall be made in accordance with the Invitation for Bids, the Proposal Forms, and these Instructions to Bidders. All bids shall be submitted on the unaltered Eastside Lane Rehabilitation Project Proposal Forms ("Proposal Forms") contained in the Project Manual with all items completely filled out with typewritten or legible handwritten responses. Signatures of all persons signing shall be in longhand. Completed Proposal Forms shall be without interlineations, alterations, or erasures.
- B. ALL BID SUBMITTALS SHALL REMAIN BOUND TOGETHER. Proposal Forms (contained herein on pages **BD-1 through BD-20**) may be separated from the Project Manual for purposes of bid submittal.
- C. Bids shall not contain any recapitulation of the work to be done. Alternative proposals will not be considered unless called for by the County. No oral, telegraphic, or telephonic proposals or modifications will be considered. Unauthorized conditions, limitations, or provisions attached to a bid will render it informal and may cause its rejection.
- D. Bidders are advised that there is limited funding available for this project. Consequently, the County has developed a base project and two additive alternatives. After bid opening, the County will determine available funding and accordingly select a project (with or without the additive alternatives) for construction; and, if it chooses to do so, the County will award a contract for construction of that project. For purposes of comparing bids and determining the apparent low bidder, however, the County will use the amount entered as the "**Bidder's Grand Total**" on page **BD-3**.
- E. Each bid is to be in accordance with the Contract Documents. Before submitting a bid, bidders shall carefully read this Project Manual, including the contents and form of the Sample Standard Agreement, and the Project Plans, and inform themselves fully as to all existing conditions and limitations, which must include a visit to the site of the work, and shall include in the bid a sum to cover the cost of all work contemplated in the Contract Documents. The submission of a bid shall be conclusive evidence that the bidder has reviewed and is satisfied as to the conditions to be encountered, as to the character, quality, and quantities of work to be performed and the materials to be furnished, and as to the requirements of the Project Manual and Project Plans. The submission of a bid shall also be conclusive evidences that the person signing the Proposal Forms is authorized to bind or obligate the bidder to any agreement.

- F. Bidders' attention is directed to the insurance and bond requirements described below and as provided in the Sample Standard Agreement. It is highly recommended that bidders confer with their respective insurance carriers or brokers to determine the availability of surety bonds, insurance certificates, and endorsements as prescribed and provided herein in advance of bid submission. If an apparent low bidder fails to comply strictly with the bonding and insurance requirements, that bidder may be disqualified from award of the contract and its bid security may be forfeited. The cost of such bonds and insurance shall be included in each bidder's bid.
- G. Each bidder shall inform itself of, and the bidder awarded the contract shall comply with, all federal, state, and local laws, statutes and ordinances relative to the execution of the work. This requirement includes, but is not limited to, applicable regulations concerning employment of labor, fair labor practices, equal opportunity, drug-free workplace, construction and building, Americans with Disabilities Act, protection of public and employee health and safety, environmental protection, the protection of natural resources, fire protection, burning and non-burning requirements, permits, fees, and similar subjects.
- H. Proposal Forms (contained herein on pages **BD-1 through BD-20** and bidder's bid security must be received in a sealed, opaque envelope clearly labeled with **MONO COUNTY CIVIC CENTER TOP LIFT ASPHALT PAVING PROJECT** printed on the outside of the envelope. Bids received unsealed or unlabeled will not be considered. Bids submitted by facsimile (fax) transmission will not be considered.
- I. To be considered, bids must be received by the Clerk of the Board of Supervisors no later than **3:00 pm, Monday, April 13, 2020** ("Bid Submission Deadline"). Bids may be mailed to the Clerk of the Board of Supervisors, P.O. Box 237, Bridgeport, California, 93517, or delivered to the office of the Clerk of the Board of Supervisors, 74 North School Street, Bridgeport, California, 93517.
- J. Bidders are advised that due to the remote nature of central Mono County, "overnight" delivery by the US Postal Service, UPS, FedEx, and other carriers is actually scheduled as a **two-day delivery**. Bidders should also take potential holiday mail delays into consideration.

#### 6. MODIFICATION OF BID

A bidder may modify its bid by written communication provided such communication is received by the Clerk of the Board of Supervisors up to, but not later than, the Bid Submission Deadline described above Paragraph 5.I. The written communication shall not reveal the bid price but shall state the amount of addition or subtraction or other modification so that the final prices or terms will not be known by the County until the sealed bid is opened.

#### 7. WITHDRAWAL OF BID

Bids may be withdrawn without prejudice by the bidder up to, but not later than, the Bid Submission Deadline described above in Paragraph 5.I. Such withdrawal may be made by written letter or by email or facsimile (fax) request. Such request shall be signed by an authorized representative of the bidder. Bids so withdrawn will be returned unopened to the bidder by the County. Bids withdrawn following bid opening shall be permitted only as allowed by the Public Contract Code and may subject the accompanying bid security to forfeiture and retention by the County as in the case of failure to execute the awarded contract as provided below. Negligence on the part of the bidder in preparing the bid shall not entitle the bidder to withdraw the bid subsequent to the County opening bid proposals.



## 8. AGREEMENT AND BONDS

- A. Bidders are required to submit, along with the Proposal Forms, a certified or cashier's check or bidder's bond in an amount of at least 10 percent (10%) of their respective bids made payable to the County of Mono. This bidder's bond or bid security shall be given as a guarantee that the bidder will enter into a contract if awarded, and may be forfeited by the successful bidder and retained by the County if the bidder refuses, neglects, or fails to enter into said contract (including a failure to provide required insurance certificates and bonds) within five (5) calendar days after provision by the County of a complete and final contract for execution by successful bidder.
- B. The successful bidder will be required to furnish a labor and materials bond (also known as a "payment bond") in an amount equal to 100 percent (100%) of the contract price, and a faithful performance bond in an amount equal to 100 percent (100%) of the contract price. In addition, the successful bidder, as the Contractor, will be required to furnish a one-year warranty bond upon project completion, pursuant to the requirements in the Sample Standard Agreement. Only surety bonds issued by an admitted surety insurer, as defined in the Sample Standard Agreement, will be accepted. Bonds shall be in a form acceptable to the Mono County Counsel; a sample of an acceptable form of each type of bond required is included in this Project Manual.
- C. The Contract Documents include a Sample Standard Agreement, which the successful bidder, as the Contractor, will be required to execute, and the insurance and bonds, which the Contractor will be required to furnish.
- D. All alterations, extensions of time, extra and additional work, and other changes authorized by the County consistent with applicable provisions of the Contract Documents, may be made without securing the consent of the surety or sureties on the contract bonds.

## 9. OPENING OF BIDS

As soon after the Bid Submission Deadline as is practicable to do so, all bids received before that deadline will be taken to the Public Works Conference Room, located on the second floor of Courthouse Annex 1, 74 North School Street, Bridgeport, California, 93517, and there publicly opened, read aloud, and recorded. All interested parties are invited to attend. Any bid received after the Bid Submission Deadline will be returned to the bidder unopened.

## 10. BID EVALUATION

After all bids are opened and publicly announced, personnel from the Department of Public Works will evaluate the bids; identify the lowest responsive bid by a responsible bidder; send a Notice of Intent to Award the contract, with a ranked tabulation of all bid amounts submitted, to the identified Bidder (copied to all Bidders); and agendize the matter for review by the Board of Supervisors. The Board of Supervisors shall determine whether to proceed to contract award or to reject all bids if it is in the public of interest to do so, and in accordance with applicable laws. If the Board of Supervisors elects to proceed to contract award, it will approve and authorize execution of a contract with the successful bidder. In the event of a discrepancy between the numeric total bid written and the numeric total bid calculated, the bid amount calculated by multiplying each item quantity by the unit price and then adding each item of the proposal shall prevail.

Bid evaluation will consist of reviewing submitted bids for responsiveness, ranking the responsive bid amounts from lowest to highest, and investigating whether the apparent low

bidder, and such other bidders as the Department of Public Works deems appropriate, appears to be a “responsible bidder.” Said investigation will involve checking each bidder’s and any listed subcontractor’s license status and eligibility to contract for public works, and may also include, a request for bidder references and/or insurance certificates, a request for documents demonstrating the bidder’s solvency and available resources to timely complete the work, and consideration of the bidder’s performance on any prior contracts with the County. The County reserves the right to waive any informality or irregularity in any bid that does not affect the contract price and provided such waiver is allowed by law.

## 11. BID PROTEST PROCEDURE

Bidders may file a protest in accordance with the directions provided herein with respect to the apparent low bid, any other bid submitted, and/or with respect to the qualifications or responsibility of the apparent low bidder, or of any other bidder.

The bid protest period shall commence immediately upon the County’s issuance of the Notice of Intent to Award the contract and shall remain open until 4:30 PM of the fifth (5th) business day following the date of the Notice of Intent to Award the contract (“Bid Protest Deadline”). All bid protests must be received by the County, as described in this Paragraph 11, by the Bid Protest Deadline. Postmarks will not be accepted. Failure to timely file a written protest by the Bid Protest Deadline shall constitute a waiver of the right to protest. Untimely protests will not be accepted or considered.

Bidders may submit protests to the County by mail, facsimile (fax), or electronically. Protests submitted by mail (USPS, UPS, FedEx, Golden State Overnight, etc.) must be addressed and delivered to the Clerk of the Board of Supervisors, c/o Mono County Department of Public Works, Attn: Garrett Higerd, 74 North School Street, Post Office Box 237, Bridgeport, California, 93517. Protests submitted by facsimile (fax) must be sent to 760.932.5441. Protests submitted electronically should be emailed to Garrett Higerd at [ghigerd@mono.ca.gov](mailto:ghigerd@mono.ca.gov).

Bid protests must be submitted in and include the following information: (1) the name of the person or entity making the protest; (2) the name of the bid project; (3) a complete statement of all legal and factual grounds for the protest; (4) any documentation supporting the protestor’s grounds for the protest; and (5) the form of relief requested and the legal basis for such relief.

If a valid protest is timely filed, the Department of Public Works shall investigate the bid protest. The protested bidder shall have three (3) business days to respond to the Department of Public Works’ investigation and to provide any information requested by the Department of Public Works. The Department of Public Works shall notify the protested bidder of any evidence reflecting upon his responsibility, afford the protested bidder an opportunity to rebut such evidence, and allow the protested bidder to present evidence in support of his qualifications to perform the contract. The Department of Public Works shall respond to the protesting party upon the conclusion of its investigation by providing the protesting party a statement of its conclusions and findings. Thereafter, the Director of the Department of Public Works shall make a recommendation to the Board of Supervisors regarding the bid protest.

In addition to other requirements related to claim presentation, the bid protest procedure described herein must be pursued and exhausted before any person or entity may commence litigation against the County, or any of its officers, agents, or employees related to or arising out of the award of a contract for the construction of the Project to a bidder whose winning bid could have been the subject of a protest as outlined above.

## 12. AWARD OR REJECTION OF BIDS

- A. After expiration of the Bid Protest Deadline, the County may, in its discretion take any of the following actions: (1) Award a contract notwithstanding the filing of a bid protest; (2) refrain from awarding a contract pending resolution of any or all bid protests; or (3) otherwise proceed as it deems appropriate, including without limitation rejecting all bids received. Further, under Public Contract Code Section 22038, the County has the option, after receiving and tabulating bids, to reject all bids and perform the work by force account if the Board of Supervisors determines, by a four-fifths vote, that the work can be performed more economically by its own employees.
- B. If it chooses to award a contract, the County shall award the contract to the bidder found responsible by the County which has submitted the lowest responsive bid. Bidders are advised that should this Invitation for Bids result in the award of a contract, any such contract will not be in force until it is approved and fully executed by the County and the successful bidder.
- C. Payment under any contract resulting from this Invitation for Bids will be consistent with the Sample Standard Agreement, a sample of which has been provided with this Invitation for Bids. Any contract awarded as a result of this Invitation for Bids will be awarded without discrimination based on race, color, religion, age, sex, sexual orientation, or national origin.
- D. Contract award, if made, is anticipated to occur within two (2) weeks after the date of bid opening but could occur up to 60 days after said date. In such an event, all bidders will be notified in writing that additional time will be required. No bid can be withdrawn during that period unless such withdrawal is authorized under the Public Contract Code and the bid security shall remain in full force and effect.
- E. The County assumes no responsibility for any costs the bidder may incur, regardless of whether or not a contract is awarded, in preparing and/or submitting a bid.

### 13. CONTRACT EXECUTION

- A. Accompanying the County's Notice of Intent to Award will be the contract for the Project, which the successful bidder will be required to execute and return, together with the required bonds and certificates of insurance, to the County within five (5) calendar days following receipt of such contract and Notice of Intent to Award. Failure to do so by the successful bidder shall be just cause for annulment of the contract award and forfeiture of the bid security, which shall be retained by the County as liquidated damages, and it is agreed by both parties that the bid security sum is a fair estimate of such failure. Signature by both parties constitutes execution of a contract for the Project.
- B. In the event the successful bidder is unable to physically deliver the required bonds and insurance certificates, and where approved in writing by the Director of the Department of Public Works, the bidder shall, prior to its commencement of the work, submit evidence satisfactory to the County that such bonds and certificates will be furnished in a timely manner.
- C. In the event of failure of the lowest responsible, responsive bidder to sign and return a contract for the Project with acceptable evidence of bonds and insurance certificates as prescribed herein, the County may award the contract to the next lowest responsible, responsive bidder, and so forth, until a fully-executed contract for the Project and acceptable bonding and insurance certificates are received by the County.
- D. The bid security of all bidders will be retained by the County until a contract for the Project is executed by the successful Bidder and evidence of bonds and insurance acceptable to

the County is received, after which those bid securities, except any that may have been forfeited, will be returned to the bidders whose proposals they accompanied.

#### 14. LISTING OF AND SUBSTITUTIONS OF SUBCONTRACTORS

- A. If awarded a contract, the successful bidder shall perform with his own organization contract work amounting to not less than 30 percent (30%) of the original total contract price. The bidder shall give his/her personal attention to the fulfillment of the contract and shall keep the work under his/her control. All persons engaged in the Project and related work will be held responsible for their work, which shall be subject to the provisions of the Project Manual and any contract executed pursuant to this Invitation for Bids.
- B. Each bidder shall in its bid or offer, set forth the name and location of the office, shop, or mill of each subcontractor who will perform work or labor or render service to the bidder in or about the construction of the work or improvement and the portion of the work which will be done by each subcontractor if the amount of the subcontractor's work will be in excess of one-half of one percent (0.5%), or Ten Thousand dollars (\$10,000.00), whichever is greater, of the bidder's bid.
- C. If the bidder fails to specify a subcontractor for any portion of the work to be performed under the contract as specified above, it shall be deemed to have agreed to perform such portion itself, and it shall not be permitted to subcontract that portion of the work except under conditions hereinafter set forth.
- D. No bidder whose bid is accepted shall, without consent of the Director of the Department of Public Works, do any of the following:
  - (1) Substitute any person as subcontractor in place of the subcontractor designated in the original bid; or
  - (2) Permit any subcontractor to be assigned or transferred or allow the work to be performed by anyone other than the original subcontractor listed in the bid; or
  - (3) Sublet or subcontract any portion of the work in excess of one-half of one percent (0.5%) of the bidder's bid as to which its original bid did not designate a subcontractor.
- E. Subletting or subcontracting any portion of the work as to which no subcontractor was designated in the original bid shall be permitted only in case of public emergency, necessity, or otherwise in accordance with the Public Contract Code, and then only after a finding has been made in writing, by the Director of the Department of Public Works, setting forth the facts constituting such emergency, necessity, or statutory basis for the substitution.
- F. If haulers are used merely to convey materials and will not excavate or load the material and if they will not apply judgment as to the suitability of the material to meet Project specifications, then they do not need to be identified on the "List of Subcontractors" in the bid forms.

#### 15. INTEREST IN MORE THAN ONE BID

No person, firm, or corporation shall be allowed to make or file or be interested in more than one bid for the same work unless alternative bids are called for. A person, firm, or corporation who has submitted a sub-proposal to a bidder or who has quoted prices on materials to a bidder, is not hereby disqualified from submitting a sub-proposal or quoting prices to other bidders.

## 16. COORDINATION WITH OTHER CONTRACTORS

Bidders are required to inform themselves fully of the conditions relating to construction and labor under which the work will be performed, and bidders must employ, as far as possible, such methods and means in the carrying out the Project and related work as will not cause any interruptions or interference with any other contractor or the operations of the facility at which the work is being performed.

## 17. SUBSTITUTIONS

Throughout the Project Manual, materials may be specified that are in short supply or that are restricted by government limitation orders. For the purpose of submitting proposals, bidders shall assume that the County will require all materials to be furnished as specified. No substitutions will be permitted until all sources or supply have been exhausted and written notice is given to the Director of the Department of Public Works stating such fact. Substituted materials shall have the written approval of the Director of the Department of Public Works, or its authorized agent, before installation in the Project.

## 18. CONTRACTOR'S LICENSING LAWS

- A. The successful bidder, as the Contractor, will be required to furnish a valid Mono County Business License issued by County's Office of the Treasurer prior to commencing the work.
- B. In order to be eligible for award of a contract for the Project, a bidder must possess either of the following classification(s) of contractor's license: (1) Class A – General Engineering; or (2) C12 – Earthwork and Paving.
- C. Attention is directed to the provisions of Article 4, Chapter 9, of the California Business and Professions Code concerning the licensing of contractors. All bidders, contractors, and subcontractors shall be licensed in accordance with the laws of the State of California and any bidder, contractor, or subcontractor not so licensed is subject to the penalties imposed by such laws. All bidders, contractors, and subcontractors shall possess the appropriate licenses to cover the above advertised work. The County will verify that the successful bidder, as well as any contractor and any subcontractor, is appropriately licensed to perform Project work designated prior to awarding any contract pursuant to this Invitation for Bids.

## 19. LABOR REQUIREMENTS

The services and work to be provided by the successful bidder, as the Contractor for this Project, constitute a "public work" within the meaning of Labor Code sections 1720 and 1720.3. Accordingly, as required by Labor Code section 1771, the successful bidder, as the Contractor, and any subcontractor under it, shall pay not less than the general prevailing rate of per diem wages ("prevailing wage") specified for each craft and classification to all workers employed in the execution of the project. Copies of prevailing wages, as determined by the Director of the Department of Industrial Relations, are available online at: [www.dir.ca.gov/OPRL/DPreWageDetermination.htm](http://www.dir.ca.gov/OPRL/DPreWageDetermination.htm) and on file at the office of the Department of Public Works, located at 74 North School Street, Bridgeport, California, 93517, and are available to any interested party upon request. These wages are not included in any part or section of the Project Manual. Changes, if any, to prevailing wage rates will be available at the same location.

No contractor or subcontractor may be listed in a bid proposal or awarded a contract for a public works project unless registered with the Department of Industrial Relations pursuant to Labor Code section 1725.5 (unless exempt under Labor Code section 1771.1). This Project is subject to compliance monitoring and enforcement by the California Department of Industrial Relations.

**20. PROJECT SCHEDULE AND LIQUIDATED DAMAGES**

The Project and all related work shall be completed by **May 15, 2020**. By submitting a bid proposal, bidder acknowledges the following: (1) that the bidder has fully read Section 14.2 of Exhibit 1 of the Sample Standard Agreement; (2) that it has had ample opportunity to consult with legal counsel and obtain an explanation of these liquidated damage provisions; (3) and that it is agreed by both parties that the successful bidder, as the Contractor, will pay Mono County liquidated damages specified in Exhibit 1 of the Sample Standard Agreement.

This page intentionally left blank

COUNTY OF MONO, DEPARTMENT OF PUBLIC WORKS

**PROPOSAL FORMS**

MONO COUNTY CIVIC CENTER  
TOP LIFT ASPHALT PAVING PROJECT

Project No. MCCC PAVING



This page intentionally left blank

**PROPOSAL FORMS**

**MONO COUNTY CIVIC CENTER TOP LIFT ASPHALT PROJECT**  
**Project No. MCCC PAVING**

Proposal of \_\_\_\_\_ (“Bidder”), organized and existing under the laws of the State of \_\_\_\_\_, doing business as \_\_\_\_\_ (e.g., “a partnership;” “a corporation;” “a sole proprietor”), as applicable to the County of Mono, (“County”). This bid proposal consists of the attached pages **BD-1 through BD-20**.

In compliance with your Invitation for Bids and Instructions to Bidders, Bidder hereby proposes to perform all work for the **MONO COUNTY CIVIC CENTER TOP LIFT ASPHALT PAVING PROJECT (“Project”)** in strict accordance with the Project Manual, which include the Instructions to Bidders, Project Plans, Special Provisions, Technical Specifications, Construction Quality Assurance Program, Agreement, any applicable addenda issued by the County’s Department of Public Works, and other Contract Documents within the time set forth therein at prices stated on the attached Bid Schedule. Prices quoted in this proposal include, but are not limited to, the cost for all labor, materials, tools, equipment, supplies, transportation, permits, services, and applicable local, state, and/or federal taxes, fees, patent rights, and/or royalties necessary to complete the Project and related work contemplated in the Project Manual and described in any contract executed pursuant to this Invitation for Bids.

By submitting this Bid Proposal, Bidder certifies (and in the case of a joint bid, each party thereto certifies as to his own organization) that this bid has been arrived at independently without consultation, communication, or agreement as to any matter relating to this bid with any other Bidder or with any competitor.

Bidder hereby agrees to commence work on the Project pursuant to any contract executed pursuant to this Invitation for Bids on or before 14 calendar days following the award of contract by the County, unless a later date is specified by the County in the Notice to Proceed, and to **fully complete the project by May 15, 2020**, pursuant to the provisions specified in any contract executed pursuant to this Invitation for Bids.

It is understood that, except for lump sum items, the quantities set forth in the Bid Schedule are approximate only and are solely for the purpose of facilitating the comparison of bids, and that the Bidder’s compensation will be computed on the basis of documented final quantities in completed work, measured as specified, whether they be more or less than those shown.

Bidder’s Company Name: \_\_\_\_\_

Company Address: \_\_\_\_\_

Office Telephone No.: \_\_\_\_\_ Fax No.: \_\_\_\_\_

Email Address: \_\_\_\_\_

Contractor’s Calif. License No.: \_\_\_\_\_ Class: \_\_\_\_\_

Mono County Business License No.: \_\_\_\_\_

Name of Company Officer: \_\_\_\_\_ Title: \_\_\_\_\_

\_\_\_\_\_  
Bidder’s Signature

\_\_\_\_\_  
Date

(Add seal if by a corporation)

This page intentionally left blank

**BID SCHEDULE**  
 MONO COUNTY CIVIC CENTER  
 TOP LIFT ASPHALT PAVING  
 Project No. MCCC PAVING

*County of Mono, Department of Public Works*

<b>Civic Center Paving</b>							<b>Base Bid</b>		
No	Spec Reference	Item	Quantity	Units	Price per Unit	Item Price			
1	1	8	Mobilization	1	LS				
2	2	13	Water Pollution Control	1	LS				
3	3	12	Traffic Control, including Traffic Control Plan	1	LS				
4	4	39	1.5-inch Hot Mix Asphalt	410	Ton				
5	5	39	3-inch Hot Mix Asphalt	80	Ton				
6	6	39	Hot Mix Asphalt Trench Patch	1	LS				
<b>Civic Center Paving - Base Bid -</b>							<b>Subtotal:</b>	-	

<b>New 5-foot Wide Sidewalk</b>				<b>Bid Alternate</b>		<b>A</b>		
No	Spec Reference	Item	Quantity	Units	Price per Unit	Item Price		
1	A1	19	Roadway Excavation (Sidewalk Area)	40	CY			
2	A2	26	4" Aggregate Base (Sidewalk Area)	18	CY			
3	A3	39	2.5-inch Hot Mix Asphalt	21	Ton			
4	A4	19	Shoulder Backing	290	LF			
<b>New 5-foot Wide Sidewalk - Bid Alternate - A</b>						<b>Subtotal:</b>	-	

<p align="center"><b>BIDDER'S GRAND TOTAL*</b></p> <p align="center"><b>(Includes Base Bid + Bid Alternate A)</b></p> <p>* County will use this total to compare bids and determine apparent low bidder. Note, County will reserve right to choose and construct the base bid with or without the addition of Bid Alternate A.</p>	
--	--

This page intentionally left blank

**ACKNOWLEDGEMENTS**

MONO COUNTY CIVIC CENTER TOP LIFT ASPHALT PAVING  
Project No. MCCC PAVING

**RECEIPT OF ADDENDA**

The County of Mono is advised that Bidder has received the following addenda for the Contract Documents, including plans, specifications, and special provisions for the above-referenced project:

Addendum Number: \_\_\_\_\_ Issuance Date: \_\_\_\_\_

Subject Matter: \_\_\_\_\_

Addendum Number: \_\_\_\_\_ Issuance Date: \_\_\_\_\_

Subject Matter: \_\_\_\_\_

Addendum Number: \_\_\_\_\_ Issuance Date: \_\_\_\_\_

Subject Matter: \_\_\_\_\_

Addendum Number: \_\_\_\_\_ Issuance Date: \_\_\_\_\_

Subject Matter: \_\_\_\_\_

If you did not receive any addenda for the above-referenced project, please initial here: \_\_\_\_\_

**ACKNOWLEDGEMENT OF SITE VISIT(S)**

The County of Mono is advised that I have visited the project site as acknowledged by my initials below. In doing so, I have made myself aware of the conditions that exist and have prepared the attached proposal accordingly.

Mono County Civic Center  Yes  No

Note: This questionnaire constitutes a part of the proposal, and signature on the signature portion of the proposal constitutes signature on this questionnaire and a declaration under penalty of perjury under the laws of the State of California that the statements made herein are true and correct. Bidders are cautioned that making a false certification may subject the certifier to criminal prosecution.

**BIDDER'S LIST OF SUBCONTRACTORS PART 1**  
MONO COUNTY CIVIC CENTER TOP LIFT ASPHALT PAVING  
Project No. MCCC PAVING

As of March 1, 2015, Contractors (and sub-contractors) wishing to bid on public works contracts shall be registered with the State Division of Industrial Relations and certified to bid on Public Works contracts.

Please register at: <https://efiling.dir.ca.gov/PWCR/ActionServlet?action=displayPWCRegistrationForm>

Listed hereinafter are the names and addresses of all subcontractors who will be employed in the completion of project work and the type of work that each will perform if the contract is awarded to the undersigned Bidder. In accordance with Title 49, Section 26.11 of the Code of Federal Regulations, and Section 4104 of the Public Contract Code of the State of California, as amended, the following information is required for each sub-contractor who will perform work amounting to more than one-half of one percent (0.5%) of my total bid, or ten thousand dollars (\$10,000), whichever is greater. As to any work in which I fail to do so, I agree to perform that portion myself or be subject to penalty under the Act.

Notes:

- A. The above statement constitutes a part of the proposal and signature on the signature portion of the bid proposal constitutes signature on this statement.
- B. Vendors or suppliers that will be providing materials only need not be listed.
- C. If further space is required, copies of this sheet or additional sheets showing the required information, as indicated below, shall be attached hereto and made a part of the proposal. Fillable pdf forms of this exhibit are available for download at:  
<http://www.dot.ca.gov/hq/LocalPrograms/lam/forms/chapter12/12b.pdf>

Subcontractor Name and Location	Line Item & Description	Subcontract Amount	Percentage of Bid Item Sub-contracted	Contractor License Number	DBE (Y/N)	DBE Cert Number	Annual Gross Receipts	
				DIR Reg Number			<\$1 million	>\$1 million
Name:							<\$1 million	>\$1 million
City, State:							<\$5 million	>\$5 million
Name:							<\$1 million	>\$1 million
City, State:							<\$5 million	>\$5 million
Name:							<\$1 million	>\$1 million
City, State:							<\$5 million	>\$5 million
Name:							<\$1 million	>\$1 million
City, State:							<\$5 million	>\$5 million
Name:							<\$1 million	>\$1 million
City, State:							<\$5 million	>\$5 million
Name:							<\$1 million	>\$1 million
City, State:							<\$5 million	>\$5 million
Name:							<\$1 million	>\$1 million
City, State:							<\$5 million	>\$5 million
Name:							<\$1 million	>\$1 million
City, State:							<\$5 million	>\$5 million

Distribution: Original-Local Agency File

COUNTY OF MONO, DEPARTMENT  
OF PUBLIC WORKS

**EXHIBIT 12B: BIDDER'S LIST OF SUBCONTRACTORS PART 2**  
MONO COUNTY CIVIC CENTER TOP LIFT ASPHALT PAVING  
Project No. MCCC PAVING

In accordance with Title 49, Section 26 of the Code of Federal Regulations, the bidder shall list all subcontractors who provided a quote or bid, but **were not selected** to participate as a subcontractor on this project.

If further space is required, copies of this sheet or additional sheets showing the required information, as indicated below, shall be attached hereto and made a part of the proposal. Fillable pdf forms of this exhibit are available for download at: <http://www.dot.ca.gov/hq/LocalPrograms/lam/forms/chapter12/12b.pdf>

Subcontractor Name and Location	Line Item & Description	Subcontract Amount	Percentage of Bid Item Sub-contracted	Contractor License Number	DBE (Y/N)	DBE Cert Number	Annual Gross Receipts	
				DIR Reg Number				
Name:							<input type="checkbox"/>	<\$1 million
City, State:							<input type="checkbox"/>	<\$5 million
							<input type="checkbox"/>	<\$10 million
							<input type="checkbox"/>	<\$15 million
								Age of Firm: ___ yrs.
Name:							<input type="checkbox"/>	<\$1 million
City, State:							<input type="checkbox"/>	<\$5 million
							<input type="checkbox"/>	<\$10 million
							<input type="checkbox"/>	<\$15 million
								Age of Firm: ___ yrs.
Name:							<input type="checkbox"/>	<\$1 million
City, State:							<input type="checkbox"/>	<\$5 million
							<input type="checkbox"/>	<\$10 million
							<input type="checkbox"/>	<\$15 million
								Age of Firm: ___ yrs.
Name:							<input type="checkbox"/>	<\$1 million
City, State:							<input type="checkbox"/>	<\$5 million
							<input type="checkbox"/>	<\$10 million
							<input type="checkbox"/>	<\$15 million
								Age of Firm: ___ yrs.
Name:							<input type="checkbox"/>	<\$1 million
City, State:							<input type="checkbox"/>	<\$5 million
							<input type="checkbox"/>	<\$10 million
							<input type="checkbox"/>	<\$15 million
								Age of Firm: ___ yrs.

Distribution: Original-Local Agency File



**DISCLOSURES AND CERTIFICATIONS**

MONO COUNTY CIVIC CENTER TOP LIFT ASPHALT PAVING  
Project No. MCCC PAVING

In conformance with Public Contract Code Section 10162, the Bidder shall complete the following questionnaire under penalty of perjury:

**PUBLIC CONTRACT CODE SECTION 10162 QUESTIONNAIRE**

Has the Bidder, or any officer or employee of the Bidder who has a proprietary interest in the Bidder, ever been disqualified, removed, or otherwise prevented from bidding on or completing a federal, state, or local government project because of a violation of law or safety regulation?

Yes: \_\_\_\_\_ No: \_\_\_\_\_

If the answer is yes, please explain the circumstances in the space provided below and/or attach separate sheet(s) as necessary, with signature affixed.

In conformance with Public Contract Code Section 10285.1 (Chapter 376, Stats.1985), the Bidder shall complete the following questionnaire under penalty of perjury:

**PUBLIC CONTRACT CODE SECTION 10285.1 QUESTIONNAIRE**

Within the past three years, has the Bidder, or any officer or employee of the Bidder who has a proprietary interest in the Bidder, ever been convicted by a court of competent jurisdiction of any charge of fraud, bribery, collusion, conspiracy, or any other act in violation of any federal or state antitrust law in connection with the bidding upon, award of, or performance of any "public works contract," as defined in Public Contract Code Section 1101, with any "public entity," as defined in Public Contract Code Section 1100, the Regents of the University of California, or the Trustees of the California State University? The term "Bidder" is understood to include any partner, member, officer, director, responsible managing officer, or responsible managing employee thereof, as referred to in Section 102985.1.

Yes: \_\_\_\_\_ No: \_\_\_\_\_

If the answer is yes, please explain the circumstances in the space provided below and/or attach separate sheet(s) as necessary, with signature affixed.

**PUBLIC CONTRACT CODE 10232 STATEMENT**

In conformance with Public Contract Code Section 10232, the Contractor, hereby states under penalty of perjury, that no more than one final unappealable finding of contempt of court by a federal court has been issued against the Contractor within the immediately preceding two-year period because of the Contractor's failure to comply with an order of a federal court which orders the Contractor to comply with an order of the National Labor Relations Board.

Note: The above Questionnaires and Statement are a part of the Proposal. Signing on the signature portion of this Proposal shall also constitute signature of this Questionnaire and Statement, and the Bidder declares under penalty of perjury under the laws of the State of California that the statements made herein are true and correct. Bidders are cautioned that making a false certification may subject the certifier to criminal prosecution.

**WORKERS' COMPENSATION CERTIFICATION**

I do hereby certify that I am aware of the provisions of the California Labor Code which requires every employer to be insured against liability for Workers' Compensation or to undertake self-insurance in accordance with the provisions of that code, and I will comply with such provisions before commencing the performance of work in this contract.

**NON-COLLUSION AFFIDAVIT**

In accordance with Title 23 United States Code Section 112 and Section 7106 of the California Public Contract Code, the Bidder declares that the bid is not made in the interest of, or on behalf of, any undisclosed person, partnership, company, association, organization, or corporation; that the bid is genuine and not collusive or sham; that the Bidder has not directly or indirectly induced or solicited any other bidder to put in a false or sham bid, and has not directly or indirectly colluded, conspired, connived, or agreed with any bidder or anyone else to put in a sham bid, or that anyone shall refrain from bidding; that the Bidder has not in any manner, directly or indirectly, sought by agreement, communication, or conference with anyone to fix the bid price of the Bidder or any other bidder, or to fix any overhead, profit, or cost element of the bid price, or of that of any other bidder, or to secure any advantage against the public body awarding the contract of anyone interested in the proposed contract; that all statements contained in the bid are true; and, further, that the Bidder has not, directly or indirectly, submitted its bid price or any breakdown thereof, or the contents thereof, or divulged information or data relative thereto, or paid, and will not pay, any fee to any corporation, partnership, company, association, organization, bid depository, or to any member or agent thereof to effectuate a collusive or sham bid, and has not paid, and will not pay, any person or entity for such purpose.

Any person executing this affidavit on behalf of a bidder that is a corporation, partnership, joint venture, limited liability company, limited liability partnership, or any other entity, hereby represents that he or she has full power to execute, and does execute this declaration on behalf of the Bidder.

Note: This questionnaire constitutes a part of the proposal, and signature on the signature portion of the proposal constitutes signature on this questionnaire and a declaration under penalty of perjury under the laws of the State of California that the statements made herein are true and correct.

**EQUAL EMPLOYMENT OPPORTUNITY COMPLIANCE CERTIFICATE**

- A. The bidder hereby certifies that he (as the contractor) and all subcontractors agree to conform to the equal opportunity clauses required by Executive Orders 10925, 11114, and 11246, as well as 41 CFR 60-1.4 Equal Opportunity Clause).
- B. The bidder certifies that within 30 days of the award of the contract, as required, the contractor and subcontractors will file an "Equal Employment Opportunity Employer Information Report EEO-1 (SF-100)" with the U.S. Department of Labor and, annually thereafter, file the same report with the U.S. Department of Labor by March 31. (If your company has filed one of these reports this year, you do not have to comply with the 30-day regulation.) Refer to [https://www.eeoc.gov/employers/eeo1survey/upload/instructions\\_form.pdf](https://www.eeoc.gov/employers/eeo1survey/upload/instructions_form.pdf) for filing requirements (SF-100).
- C. The contractor and all subcontractors shall certify that prior reports have been filed under the applicable filing requirements as follows:
  - a. Contractor/Subcontractor has held previous contracts where EEO provisions were in force.  
Yes \_\_\_\_\_ No \_\_\_\_\_ (If yes, answer question 2 also)
  - b. Contractor/Subcontractor has filed all "required" reports for these previous contracts.  
Yes \_\_\_\_\_ No \_\_\_\_\_

Proposed prime contractors and subcontractors who have participated in a previous contract or subcontract subject to Executive Orders 10925, 11114, and 11246 and that have not filed reports when required should note that 41 CFR 60-1.7 (b) (1) prevents the award of contracts and subcontracts unless such contractor (and/or subcontractor) submits a report covering the delinquent period or such other period specified by the Federal Highway Administration or by the Director of the U.S. Department of Labor's Office of Federal Contract Compliance.

If the bidder has participated in a previous contract subject to the equal opportunity clause and has not submitted compliance reports due under applicable filing requirements, the Bidder shall submit a compliance report on Standard Form 100, "Employee Information Report EEO-1" prior to the award of any contract issued pursuant to this IFB.

- D. This certification is required by the Equal Employment Opportunity Regulations of the Secretary of the Department of Labor (41 CFR 60-1.7(b) (1)) and must be submitted by bidders and proposed subcontractors only in connection with contracts and subcontracts which are subject to the equal opportunity clause. Contracts and subcontracts which are exempt from the equal opportunity clause are set forth in 41 CFR 60-1.5 (generally only contracts or subcontracts of \$10,000 or less are exempt).
- E. Contractor/Subcontractor certifies that he is not currently in receipt of any outstanding letters of deficiency, show cause, probable cause, or other such Notification of Noncompliance with EEO regulations.
- F. A compliance certificate in conformance with this section is not required at time of bid, but each subcontractor must be provide this certificate to the County prior to execution of any contract issued pursuant to this IFB. If available, subcontractor certificates may be supplied at time of bid. Subcontractor signature below certifies Equal Employment Opportunity compliance. Each subcontractor shall answer the questions in Item C above and sign a copy of this page.

\_\_\_\_\_  
Subcontractor Name

\_\_\_\_\_  
Subcontractor Signature

\_\_\_\_\_  
Date

Note: This Certificate constitutes a part of the proposal, and the contractor's signature on the signature portion of the proposal constitutes the Contractor's "Equal Employment Opportunity Compliance Certificate" and a declaration under penalty of perjury under the laws of the State of California that the statements made herein are true and correct.

**DEBARMENT AND SUSPENSION CERTIFICATION**

## TITLE 49, CODE OF FEDERAL REGULATIONS, PART 29

The Bidder, under penalty of perjury, certifies that, except as noted below, she/he or any other person associated therewith in the capacity of owner, partner, director, office manager:

- Is not currently under suspension, debarment, voluntary exclusion, or determination of ineligibility by any federal agency;
- Has not been suspended, debarred, voluntarily excluded or determined ineligible by any federal agency within the past three (3) years;
- Does not have a proposed debarment pending; and
- Has not been indicated, convicted, or had a civil judgment rendered against it by a court of competent jurisdiction in any matter involving fraud or official misconduct within the past three (3) years.

If there are any exceptions to this certification, insert the exception in the following space:

Exceptions will not necessarily result in denial of award, but will be considered in determining bidder responsibility. For any exception noted above, indicate below to whom it applies, initiating agency, and dates of actions.

Providing false information may result in criminal prosecution or administrative sanction. The above certification is part of the Proposal. Signing this Proposal on the signature portion hereof shall also constitute signature of this certification and a declaration under penalty of perjury under the laws of the State of California that the statements made herein are true and correct.

Note: This questionnaire constitutes a part of the proposal, and signature on the signature portion of the proposal constitutes signature on this questionnaire and a declaration under penalty of perjury under the laws of the State of California that the statements made herein are true and correct.

**BIDDER'S QUALIFICATION STATEMENT**  
MONO COUNTY CIVIC CENTER TOP LIFT ASPHALT PAVING  
Project No. MCCC PAVING

This Qualifications Statement will be used by Mono County to determine if a Bidder is qualified to do the work to be performed and therefore to find if the Bidder is a "responsible" bidder. The Qualifications Statement should be completed on behalf of the Bidder by an officer or other individual who is knowledgeable about the Bidder's past and current operations, policies, and practices. A response must be provided to each question. If a particular question does not apply, the response should state "not applicable" or "N/A". **Qualifications statements that contain missing or incomplete answers may render the proposal non-responsive.** The County reserves the right, however, to allow the bidder to submit additional information pertaining to its qualifications after the Bid Submission Deadline provided in the Project Manual if circumstances warrant and to waive any error or defect in a Bidder's Qualification Statement.

Answers may be expanded upon by attaching additional pages. Use 8½" x 11" paper and mark each additional page with the Bidder's name and identification of the particular question to which an answer is being given. For the purposes of this Qualification Statement, the terms "company," "firm," "bidder," "proposer," and "contractor" are used interchangeably and have the same meaning.

The following documents or information must be included with your Qualifications Statement for this Bid Proposal. (Existing certification and license information on file with the County and current may meet the requirements of this section subject to verification prior to award of any contract):

Insurance: Contractor must provide proof that the firm is insured at least to the limits identified in the Sample Standard Agreement.

Licenses: Copies of all applicable and current trade licenses issued to the Contractor which legally allow the Contractor to perform the work identified for this Project.

Previous Work History: This Qualifications Statement includes a form titled "Experience on Completed or Ongoing Projects." Please use this form to detail the work that the firm has performed within the last three (3) years. A minimum of three (3) successfully-completed general civil and/or asphalt concrete pavement maintenance construction projects are required. Use one (1) page per project and reproduce copies of the form as necessary. In each project description, identify your firm as a prime contractor, subcontractor, or joint venture partner.

OSHA Violations: If at any time within the past five (5) years the Contractor has received an OSHA serious violation, you must provide copies of the *Citation and Notification of Penalty*, signed *Settlement Agreement*, and narrative which details the specific issue(s) cited, remedial action required and taken by the Contractor, amount of fine initially imposed, and ultimate resolution.

Resumes and Organizational Chart: The Contractor must include current resumes for each principal and key individual identified in Question 2B below. The statement must also include a copy of the firm's current organizational chart.

Equipment: The Contractor must provide a list of equipment that would be available for the work.

**1. GENERAL INFORMATION:**

A. Type of organization: \_\_\_\_\_

If Corporation, include year and state incorporated

If Partnership, state whether general or limited

If Sole Proprietorship, include name of owner

If Joint Venture\*, include name all partnering firms

\* Bidder's submitting a bid as joint venture must obtain a joint venture contractor's license before they may be awarded a contract, per Business and Professions Code §7029.1.

B. Is the firm, and all persons or firms listed in the bid as subcontractors, registered with the Department of Industrial Relations as required by California Labor Code section 1725.5?

\_\_\_\_\_ Yes

\_\_\_\_\_ No

C. If you checked "No" in the previous question, then you must fall within one of the limited exceptions set forth in California Labor Code section 1771.1, and must register with the Department of Industrial Relations prior to contract award. Does the firm (or any subcontractor) fall within California Labor Code section 1771.1 and become registered prior to contract award?

\_\_\_\_\_ Yes (attach explanation)

\_\_\_\_\_ No (not qualified)

**2. PERSONNEL:**

A. Identify the current number of employees below:

Employee Type	Full-Time	Part-Time
Office		
Field		

B. Principals and Key Personnel: On the chart below, supply the required information. Principals and key personnel include proprietors, partners, directors or officers of the firm; any manager or individual who participates in overall policy-making or financial decisions of the firm; any person who makes significant financial contributions to the firm's operations; any person in a position to control and direct the firm's overall operations or any significant part of its operation (including site foremen and superintendents). Resumes for principals and key personnel must be provided herewith. Use additional sheets if necessary to identify all principals and key personnel.

Description	Person 1	Person 2	Person 3
Name			
Title			
% Ownership			

(Use additional sheets if necessary to identify all Principals and Key Personnel)

**3. FINANCIAL INFORMATION:**

- A. Are there any liens outstanding against the Contractor?  
(if yes, provide a detailed explanation on an attached sheet)  Yes  No
- B. Has the Contractor, principals, or key personnel been party to a  
bankruptcy or reorganization proceeding with the last five years?  
(if yes, provide a detailed explanation on an attached sheet)  Yes  No
- C. Annual sales dollar volume of Contractor: \$ \_\_\_\_\_

**4. INTEGRITY OF CONTRACTOR:** Please provide an explanation on an attached sheet for any of the following questions with the answer "yes".

- A. During the past five years has the Contractor:
  - i. Been subject of a lien or claim of \$25,000 or more by a subcontractor or supplier?  Yes  No
  - ii. Failed to complete a contract?  Yes  No
  - ii. Been suspended, debarred, disqualified or otherwise declared ineligible to bid?  Yes  No
  - iv. Been defaulted on any contract?  Yes  No
  - v. Had a contract terminated?  Yes  No
  - vi. Had liquidated damages assessed against it upon completion of a contract?  Yes  No
  - vii. Been a plaintiff or defendant in any lawsuits arising out of public or private construction contracts?  Yes  No
- B. During the past five years has the Contractor, Principals or Key Personnel:
  - i. Been a plaintiff or defendant in any lawsuits arising out of public or private construction contracts?  Yes  No
  - ii. Been the subject of an investigation involving any alleged violation of criminal law, civil antitrust law or other federal, state, or local civil law?  Yes  No
  - iii. Been convicted after trial or by plea of any felony under state or federal law?  Yes  No
  - iv. Entered a plea of nolo contendere to a charge of embezzlement, theft, forgery, bribery, falsification or destruction of records, receiving stolen property or violation of an antitrust law?  Yes  No
  - v. Been the subject of an investigation of any alleged violation of federal, state, or local regulations by any public agency?  Yes  No

- vi. Been found to have committed a violation of any labor law or regulation including prevailing wage rates and fair labor practices?  Yes  No
- vii. Been found to have committed an OSHA "serious violation"?  Yes  No
- vii. Been found to have committed a construction-related violation of federal, state, or local environmental law or regulation?  Yes  No

**5. BIDDING CAPABILITY AND PREVIOUS EXPERIENCE:**

A. Provide a detailed narrative of the Contractor's experience and involvements in asphalt concrete pavement preservation, maintenance, and rehabilitation projects. Previous experience in this field of construction is necessary for the Contractor to be found responsible specific to this Project. Additional information can be provided on an attached sheet.

---

---

---

---

---

---

---

---

---

---

---

---

---

---

---

---

---

---

---

---

---

---

---

---

---

---

mark if continued on an attached sheet



B. Identify Contractor specialty capabilities (check all appropriate). Bidder must have self-performing capability for each specialty selected.

- |  |   |
|--|---|
| <input type="checkbox"/> 1. Concrete Work                        | <input type="checkbox"/> 13. Asphalt-Rubber Chip Seal         |
| <input type="checkbox"/> 2. Asphalt Concrete Reconstruction      | <input type="checkbox"/> 14. Asphalt Concrete Tack Coat       |
| <input type="checkbox"/> 3. Roadway Subgrade Stabilization       | <input type="checkbox"/> 15. Hot In-Place Recycling           |
| <input type="checkbox"/> 4. Asphalt Concrete Paving              | <input type="checkbox"/> 16. Cold In-Place Recycling          |
| <input type="checkbox"/> 5. Asphalt Concrete Overlays            | <input type="checkbox"/> 17. Roadway Sign Installation        |
| <input type="checkbox"/> 6. Roadway Grinding / Pulverizing       | <input type="checkbox"/> 18. Grading and Earthwork            |
| <input type="checkbox"/> 7. Full Depth Reclamation               | <input type="checkbox"/> 19. Erosion Control Protection       |
| <input type="checkbox"/> 8. Asphalt Concrete Cape Seal           | <input type="checkbox"/> 20. Traffic Control                  |
| <input type="checkbox"/> 9. Asphalt Concrete Micro-Surfacing     | <input type="checkbox"/> 21. Roadway Paint Striping / Marking |
| <input type="checkbox"/> 10. Asphalt Concrete Slurry Sealing     | <input type="checkbox"/> 22. Guardrail Installation / Repair  |
| <input type="checkbox"/> 11. Asphalt Concrete Fog Sealing        | <input type="checkbox"/> 23. Drainage / Culvert Installation  |
| <input type="checkbox"/> 12. Polymer Modified Emulsion Chip Seal | <input type="checkbox"/> 24. Utility Placement & Trenching    |

C. Contract capability (determined by size of previous work and bonding capacity):

- 1. \$0 - \$10,000
- 2. \$0 - \$50,000
- 3. \$0 - \$100,000
- 4. \$0 - \$250,000
- 5. \$0 - \$500,000
- 6. \$0 - \$1,000,000
- 7. \$0 - \$5,000,000
- 8. \$0 - \$10,000,000
- 9. \$0 - >\$10,000,000

D. Use the following form (Page BD-18) to describe Bidder's experience on completed or ongoing projects over the last five (5) years. A separate sheet must be completed for each project; a minimum of three (3) projects are required.

PROJECT EXPERIENCE WITH ROAD PRESERVATION, MAINTENANCE AND REHABILITATION PROJECTS

Project Status:
 Project completed
 Work in progress

Contractor's Role\*:
 Prime Contractor
 Subcontractor
 Joint Venture Partner

\* Entity submitting proposal is considered "Contractor"

Facility / Project Name: \_\_\_\_\_

Address of Project: \_\_\_\_\_

Project Owner: \_\_\_\_\_

Contract Amount (Contractor's Share): \$\_\_\_\_\_ Was project bonded?  Yes  No

% of total project performed by Contractor by Contractor's own forces: \_\_\_\_\_%

Was Contractor required to possess a Performance Bond and/or Payment Bond?  Yes  No

Start Date:\_\_\_\_\_ Scheduled Completion Date:\_\_\_\_\_ Actual Completion Date:\_\_\_\_\_

Construction Manager / Project Manager:

Company: \_\_\_\_\_

Address: \_\_\_\_\_

Telephone:\_\_\_\_\_ email: \_\_\_\_\_

Contact Name:\_\_\_\_\_ Title: \_\_\_\_\_

Architect / Engineer:

Company: \_\_\_\_\_

Address: \_\_\_\_\_

Telephone:\_\_\_\_\_ email: \_\_\_\_\_

Contact Name:\_\_\_\_\_ Title: \_\_\_\_\_

Reference familiar with Contractor's performance:

Company: \_\_\_\_\_

Address: \_\_\_\_\_

Telephone:\_\_\_\_\_ email: \_\_\_\_\_

Contact Name:\_\_\_\_\_ Title: \_\_\_\_\_

Description of work performed by Contractor: \_\_\_\_\_

\_\_\_\_\_

# **BID BOND**

*(MINIMUM 10% OF TOTAL BID AMOUNT)*

KNOW ALL BY THESE PRESENTS that we, \_\_\_\_\_  
the Contractor in the contract hereto annexed, as Principal, and \_\_\_\_\_,  
as Surety, jointly and severally, bind ourselves, our heirs, representatives, successors and assigns, as  
set forth herein to the County of Mono (hereinafter, "Owner") in the sum of \$ \_\_\_\_\_  
lawful money of the United States. Principal has submitted the accompanying bid for

## **MONO COUNTY CIVIC CENTER TOP LIFT ASPHALT PAVING PROJECT**

If the Principal is awarded the contract and enters into a written contract, in the form prescribed by the Owner, at the price designated by his bid, and files two bonds with the Owner, one to guarantee payment for labor and materials and the other to guarantee faithful performance, in the time and manner specified by the Owner, and carries all insurance in the type and amount which conforms to the Contract Documents, and furnishes required certificates and endorsements thereof, then this obligation shall be null and void; otherwise it shall remain in full force and effect.

Forfeiture of this bond shall not preclude the Owner from seeking all other remedies provided by law to cover losses sustained as a result of the Principal's failure to do any of the foregoing.

Principal and Surety agree that if the Owner is required to engage the services of an attorney in connection with the enforcement of this bond, each shall pay Owner's reasonable attorney's fees incurred with or without suit.

PRINCIPAL:

Executed on: \_\_\_\_\_

By: \_\_\_\_\_

(Seal of Corporation)

Title: \_\_\_\_\_

(Attach notary acknowledgment for Contractor's authorized representative and for Attorney-in-Fact of Surety)

NOTICE: No substitution or revision to this bond form will be accepted. Sureties must be authorized to do business in and have an agent for service of process in California. A certified copy of Power of Attorney must be attached.

Any claims under this bond may be addressed to:

\_\_\_\_\_ (Name and address of Surety)

\_\_\_\_\_

\_\_\_\_\_

\_\_\_\_\_

\_\_\_\_\_

\_\_\_\_\_ (Name and address of Surety's agent for service of process in California, if different from above)

\_\_\_\_\_

\_\_\_\_\_

\_\_\_\_\_ (Telephone number of Surety's agent in Calif.)

(Attach notary acknowledgement)

\_\_\_\_\_  
SURETY

By: \_\_\_\_\_  
(Attorney-in-Fact)

This page intentionally left blank

## **SECTION II**



### **SAMPLE STANDARD AGREEMENT**

**Mono County Civic Center  
Top Lift Asphalt Paving Project**

**Project No. MCCC PAVING**

This page intentionally left blank

**AGREEMENT BETWEEN COUNTY OF MONO AND**  
 Click here to enter text. **FOR THE CONSTRUCTION OF THE**  
**MONO COUNTY CIVIC CENTER TOP LIFT ASPHALT PAVING**  
**PROJECT**

**INTRODUCTION**

WHEREAS, the County of Mono (“County”) may have the need for the Click here to enter text. services of Click here to enter text., of Click here to enter text. (“Contractor”) (County and Contractor may be referred to individually as a “Party” and collectively as the “Parties”), and in consideration of the mutual promises, covenants, terms and conditions hereinafter contained, the Parties hereby agree as follows:

**TERMS AND CONDITIONS**

**1. SCOPE OF WORK**

Contractor shall furnish to County, upon its request, those services and work set forth in the Scope of Work set forth in Attachment A, attached hereto and by this reference incorporated herein, and in accordance with the Project Manual (including technical specifications) and Contractor’s bid. Requests by County to Contractor to perform under this Agreement will be made by the Director of the Department of Public Works or an authorized representative thereof. Requests to Contractor for services or work to be performed under this Agreement will be based upon County's need for such services and work. County makes no guarantee or warranty, of any nature, that any minimum level or amount of services or work will be requested of Contractor by County under this Agreement. By this Agreement County incurs no obligation or requirement to request from Contractor the performance of any services or work at all, even if County should have some need for such services or work during the term of this Agreement.

Services and work provided by Contractor at County's request under this Agreement will be performed in a manner consistent with the requirements and standards established by applicable federal, state, and county laws, ordinances, and resolutions including, but not limited to, those that are referred to in this Agreement.

This Agreement is subject to the following Exhibits (as noted) which are attached hereto, following all referenced Attachments, and incorporated herein by this reference:

- Exhibit 1:** General Conditions (Construction)
- Exhibit 2:** Prevailing Wages
- Exhibit 3:** Bond Requirements
- Exhibit 4:** Invoicing, Payment, and Retention
- Exhibit 5:** Trenching Requirements
- Exhibit 6:** FHWA Requirements
- Exhibit 7:** CDBG Requirements
- Exhibit 8:** HIPAA Business Associate Agreement
- Exhibit 9:** Other \_\_\_\_\_

In the event of a conflict between the terms of an attached Exhibit and this Agreement, the terms of the Exhibit shall govern.

**2. TERM**

The term of this Agreement shall be from Click here to enter text., to Click here to enter text., unless sooner terminated as provided in this Agreement.

**3. CONSIDERATION**

A. Compensation. County shall pay Contractor in accordance with the Schedule of Fees set forth in Attachment B for the services and work described in Attachment A that are performed by Contractor at County’s request.



- B. Travel and Per Diem. Contractor will not be paid or reimbursed for travel expenses or per diem that Contractor incurs in providing services and work requested by County under this Agreement, unless otherwise provided for in Attachment B.
- C. No Additional Consideration. Except as expressly provided in this Agreement, Contractor shall not be entitled to, nor receive, from County, any additional consideration, compensation, salary, wages, or other type of remuneration for services rendered under this Agreement. Specifically, Contractor shall not be entitled, by virtue of this Agreement, to consideration in the form of overtime, health insurance benefits, retirement benefits, disability retirement benefits, sick leave, vacation time, paid holidays, or other paid leaves of absence of any type or kind whatsoever.
- D. Limit upon amount payable under Agreement. The total sum of all payments made by County to Contractor for services and work performed under this Agreement shall not exceed [Click here to enter text.](#) dollars ([Click here to enter text.](#)), or [Click here to enter text.](#) dollars ([Click here to enter text.](#)) in any twelve-month period, plus (for public works contracts) the amount of any change order(s) approved in accordance with authority delegated by the Board of Supervisors (collectively, the "Contract Limit"). The County expressly reserves the right to deny any payment or reimbursement requested by Contractor for services or work performed that is in excess of the Contract Limit.
- E. Billing and Payment. Contractor shall submit to County, on a monthly basis, an itemized statement of all services and work described in Attachment A, completed at the County's request. The statement to be submitted will cover the period from the first (1st) day of the preceding month through and including the last day of the preceding month. Alternatively, Contractor may submit a single request for payment corresponding to a single incident of service or work performed at County's request. All statements submitted in request for payment shall identify the date on which the services and work were performed and describe the nature of the services and work which were performed on each day. Invoicing shall be informative but concise regarding services and work performed during that billing period. Upon finding that Contractor has satisfactorily completed the work and performed the services as requested, the County shall make payment to Contractor within 30 days of its receipt of the itemized statement. Should County determine the services or work have not been completed or performed as requested and/or should Contractor produce an incorrect statement, County shall withhold payment until the services and work are satisfactorily completed or performed and/or the statement is corrected and resubmitted.
- If Exhibit 4 ("Invoicing, Payment, and Retention") is attached to this Agreement, then the language contained in Exhibit 4 shall supersede and replace this Paragraph 3.E. in its entirety.
- F. Federal and State Taxes.
- (1) Except as provided in subparagraph (2) below, County will not withhold any federal or state income taxes or social security from any payments made by County to Contractor under the terms and conditions of this Agreement.
  - (2) County shall withhold California state income taxes from payments made under this Agreement to non-California resident independent contractors when it is anticipated that total annual payments to Contractor under this Agreement will exceed One Thousand Four Hundred Ninety-nine dollars (\$1,499.00).
  - (3) Except as set forth above, County has no obligation to withhold any taxes or payments from sums paid by County to Contractor under this Agreement. Payment of all taxes and other assessments on such sums is the sole responsibility of Contractor. County has no responsibility or liability for payment of Contractor's taxes or assessments.
  - (4) The total amounts paid by County to Contractor, and taxes withheld from payments to non-California residents, if any, will be reported annually to the U.S. Internal Revenue Service and the California State Franchise Tax Board.

#### 4. WORK SCHEDULE

Contractor's obligation is to perform, in a timely manner, those services and work identified in Attachment A that are requested by County. It is understood by Contractor that the performance of these services and work will require a varied schedule. Contractor, in arranging his/her schedule, will coordinate with County to ensure that all services and work requested by County under this Agreement will be performed within the time frame set forth by County.

#### 5. REQUIRED LICENSES, CERTIFICATES, AND PERMITS

Any licenses, certificates, or permits required by the federal, state, county, or municipal governments, for Contractor to provide the services and work described in Attachment A must be procured by Contractor and be valid at the time Contractor enters into this Agreement. Further, during the term of this Agreement, Contractor must maintain such licenses, certificates, and permits in full force and effect. Licenses, certificates, and permits may include, but are not limited to, driver's licenses, professional licenses or certificates, and business licenses. Such licenses, certificates, and permits will be procured and maintained in force by Contractor at no expense to County. Contractor will provide County, upon execution of this Agreement, with evidence of current and valid licenses, certificates and permits that are required to perform the services identified in Attachment A. Where there is a dispute between Contractor and County as to what licenses, certificates, and permits are required to perform the services identified in Attachment A, County reserves the right to make such determinations for purposes of this Agreement.

#### 6. OFFICE SPACE, SUPPLIES, EQUIPMENT, ETC

Contractor shall provide such office space, supplies, equipment, vehicles, reference materials, support services and telephone service as is necessary for Contractor to provide the services identified in Attachment A to this Agreement. County is not obligated to reimburse or pay Contractor for any expense or cost incurred by Contractor in procuring or maintaining such items. Responsibility for the costs and expenses incurred by Contractor in providing and maintaining such items is the sole responsibility and obligation of Contractor.

#### 7. COUNTY PROPERTY

A. Personal Property of County. Any personal property such as, but not limited to, protective or safety devices, badges, identification cards, keys, uniforms, vehicles, reference materials, furniture, appliances, etc. provided to Contractor by County pursuant to this Agreement is, and at the termination of this Agreement remains, the sole and exclusive property of County. Contractor will use reasonable care to protect, safeguard and maintain such items while they are in Contractor's possession. Contractor will be financially responsible for any loss or damage to such items, partial or total that is the result of Contractor's negligence.

B. Products of Contractor's Work and Services. Any and all compositions, publications, plans, designs, specifications, blueprints, maps, formulas, processes, photographs, slides, videotapes, computer programs, computer disks, computer tapes, memory chips, soundtracks, audio recordings, films, audio-visual presentations, exhibits, reports, studies, works of art, inventions, patents, trademarks, copyrights, or intellectual properties of any kind that are created, produced, assembled, compiled by, or are the result, product, or manifestation of, Contractor's services or work under this Agreement are, and at the termination of this Agreement remain, the sole and exclusive property of the County. At the termination of the Agreement, Contractor will convey possession and title to all such properties to County.

#### 8. WORKERS' COMPENSATION

Contractor shall provide Statutory Workers' Compensation insurance coverage and Employer's Liability coverage for not less than One Million dollars (\$1,000,000.00) per occurrence for all employees engaged in services or operations under this Agreement. Any insurance policy limits in excess of the specified minimum limits and coverage shall be made available to County as an additional insured. The Workers' Compensation policy shall be endorsed with a waiver of subrogation in favor of County for all work performed by Contractor, its employees, agents, and subcontractors.

## 9. INSURANCE

A. Contractor shall procure and maintain for the duration of the contract, and for five (5) years thereafter, insurance (as noted) against claims for injuries to persons or damages to property which may arise from or in connection with the performance of the work hereunder and the results of that work by Contractor, its agents, representatives, employees, or subcontractors.

### MINIMUM SCOPE AND LIMITS OF INSURANCE

Coverage shall be at least as broad as:

- Commercial General Liability. A policy of Comprehensive General Liability Insurance which covers all the work and services to be performed by Contractor under this Agreement, including operations, products and completed operations, property damage, bodily injury (including death) and personal and advertising injury. Such policy shall provide limits of not less than Five Million dollars (\$5,000,000.00) per claim or occurrence. If a general aggregate limit applies, either the general aggregate limit shall apply separately to this project or the general aggregate limit shall be twice the required occurrence limit.
- Automobile Liability Insurance. A policy of Comprehensive Automobile/Aircraft/Watercraft Liability Insurance for bodily injury (including death) and property damage which provides total limits of not less than Five Million dollars (\$5,000,000.00) per claim or occurrence applicable to all owned, non-owned and hired vehicles/aircraft/watercraft. If the services provided under this Agreement include the transportation of hazardous materials/wastes, then the Automobile Liability policy shall be endorsed to include Transportation Pollution Liability insurance covering materials/wastes to be transported by Contractor pursuant to this Agreement. Alternatively, such coverage may be provided in Contractor's Pollution Liability policy.
- Professional Errors and Omissions Liability Insurance. A policy of Professional Errors and Omissions Liability Insurance appropriate to Contractor's profession in an amount of not less than One Million dollars (\$1,000,000.00) per claim or occurrence or Two Million dollars (\$2,000,000.00) general aggregate. If coverage is written on a claims-made form then: (1) the "retro date" must be shown, and must be before the beginning of contract work; (2) insurance must be maintained and evidence of insurance must be provided for at least five years after completion of the contract work; and (3) if coverage is cancelled or non-renewed, and not replaced with another claims-made policy form with a "retro date" prior to the contract effective date, then Contractor must purchase "extended reporting" coverage for a minimum of five years after completion of contract work.
- Pollution Liability Insurance. A policy of Comprehensive Contractor's Pollution Liability coverage applicable to the work being performed and covering Contractor's liability for bodily injury (including death), property damage, and environmental damage resulting from "sudden accidental" or "gradual" pollution and related cleanup costs arising out of the work or services to be performed under this Agreement. Coverage shall provide a limit no less than One Million dollars (\$1,000,000.000) per claim or occurrence and Two Million dollars (\$2,000,000.00) policy aggregate. If the services provided involve lead-based paint or asbestos identification/remediation, the Pollution Liability policy shall not contain lead-based paint or asbestos exclusions.

B. Coverage and Provider Requirements. Insurance policies shall not exclude or except from coverage any of the services and work required to be performed by Contractor under this Agreement. The required polic(ies) of insurance shall be issued by an insurer authorized to sell such insurance by the State of California, and have at least a "Best's" policyholder's rating of "A" or "A+". Prior to commencing any work under this agreement, Contractor shall provide County: (1) a certificate of insurance evidencing the coverage required; (2) an additional insured endorsement for general liability applying to the County of Mono, its agents, officers and employees made on ISO form CG 20 10 11 85, or providing equivalent coverage; and (3) a notice of cancellation or change of

coverage endorsement indicating that the policy will not be modified, terminated, or canceled without 30 days written notice to County.

C. Deductible, Self-Insured Retentions, and Excess Coverage. Any deductibles or self-insured retentions must be declared and approved by County. If possible, the Insurer shall reduce or eliminate such deductibles or self-insured retentions with respect to County, its officials, officers, employees, and volunteers; or the Contractor shall provide evidence satisfactory to County guaranteeing payment of losses and related investigations, claim administration, and defense expenses. Any insurance policy limits in excess of the specified minimum limits and coverage shall be made available to County as an additional insured.

D. Subcontractors. Contractor shall require and verify that all subcontractors maintain insurance (including Workers' Compensation) meeting all the requirements stated herein and that County is an additional insured on insurance required of subcontractors.

## 10. STATUS OF CONTRACTOR

All acts of Contractor, its agents, officers, and employees, relating to the performance of this Agreement, shall be performed as an independent contractor, and not as an agent, officer, or employee of County. Contractor, by virtue of this Agreement, has no authority to bind or incur any obligation on behalf of, or exercise any right or power vested in, County, except as expressly provided by law or set forth in Attachment A. No agent, officer, or employee of County is to be considered an employee of Contractor. It is understood by both Contractor and County that this Agreement shall not, under any circumstances, be construed to create an employer-employee relationship or a joint venture. As an independent contractor:

A. Contractor shall determine the method, details, and means of performing the work and services to be provided by Contractor under this Agreement.

B. Contractor shall be responsible to County only for the requirements and results specified in this Agreement, and except as expressly provided in this Agreement, shall not be subjected to County's control with respect to the physical action or activities of Contractor in fulfillment of this Agreement.

C. Contractor, its agents, officers and employees are, and at all times during the term of this Agreement shall represent and conduct themselves as, independent contractors, and not employees of County.

## 11. DEFENSE AND INDEMNIFICATION

Contractor shall defend with counsel acceptable to County, indemnify, and hold harmless County, its agents, officers, and employees from and against all claims, damages, losses, judgments, liabilities, expenses, and other costs, including litigation costs and attorney's fees, arising out of, resulting from or in connection with, the performance of this Agreement by Contractor, or Contractor's agents, officers, or employees. Contractor's obligation to defend, indemnify, and hold the County, its agents, officers, and employees harmless applies to any actual or alleged personal injury, death, damage or destruction to tangible or intangible property, including the loss of use. Contractor's obligation under this paragraph extends to any claim, damage, loss, liability, expense, or other costs that are caused in whole or in part by any act or omission of the Contractor, its agents, employees, supplier, or anyone directly or indirectly employed by any of them, or anyone for whose acts or omissions any of them may be liable.

Contractor's obligation to defend, indemnify, and hold the County, its agents, officers, and employees harmless under the provisions of this paragraph is not limited to, or restricted by, any requirement in this Agreement for Contractor to procure and maintain a policy of insurance and shall survive any termination or expiration of this Agreement.

## 12. RECORDS AND AUDIT

A. Records. Contractor shall prepare and maintain all records required by the various provisions of this Agreement, federal, state, county, municipal, ordinances, regulations, and directions. Contractor shall maintain these

records for a minimum of four (4) years from the termination or completion of this Agreement. Contractor may fulfill its obligation to maintain records as required by this paragraph by substitute photographs, micrographs, or other authentic reproduction of such records.

B. Inspections and Audits. Any authorized representative of County shall have access to any books, documents, papers, records, including, but not limited to, financial records of Contractor, that County determines to be pertinent to this Agreement, for the purposes of making audit, evaluation, examination, excerpts, and transcripts during the period such records are to be maintained by Contractor. Further, County has the right, at all reasonable times, to audit, inspect, or otherwise evaluate the work performed or being performed under this Agreement.

### **13. NONDISCRIMINATION**

During the performance of this Agreement, Contractor, its agents, officers, and employees shall not unlawfully discriminate in violation of any federal, state, or local law, against any employee, or applicant for employment, or person receiving services under this Agreement, because of race, religious creed, color, ancestry, national origin, physical disability, mental disability, medical condition, marital status, sex, age, or sexual orientation. Contractor and its agents, officers, and employees shall comply with the provisions of the Fair Employment and Housing Act (Government Code section 12900, et seq.), and the applicable regulations promulgated thereunder in the California Code of Regulations. Contractor shall also abide by the Federal Civil Rights Act of 1964 (P.L. 88-352) and all amendments thereto, and all administrative rules and regulations issued pursuant to said Act.

### **14. TERMINATION**

This Agreement may be terminated by County without cause, and at will, for any reason by giving to Contractor 30 calendar days written notice of such intent to terminate. Contractor may terminate this Agreement without cause, and at will, for any reason whatsoever by giving to County 30 calendar days written notice of such intent to terminate.

Notwithstanding the foregoing, if this Agreement is subject to General Conditions (set forth as an Exhibit hereto), then termination shall be in accordance with the General Conditions and this Paragraph 14 shall not apply.

### **15. ASSIGNMENT**

This Agreement is an agreement for the personal services of Contractor. County has relied upon the skills, knowledge, experience, and training of Contractor as an inducement to enter into this Agreement. Contractor shall not assign or subcontract this Agreement, or any part of it, without the express written consent of the County. Further, Contractor shall not assign any moneys due or to become due under this Agreement without the prior written consent of County.

### **16. DEFAULT**

If Contractor abandons the work, or fails to proceed with the work and services requested by County in a timely manner, or fails in any way as required to conduct the work and services as required by County, County may declare Contractor in default and terminate this Agreement upon five (5) days written notice to Contractor. Upon such termination by default, County will pay to Contractor all amounts owing to Contractor for services and work satisfactorily performed to the date of termination.

### **17. WAIVER OF DEFAULT**

Waiver of any default by either party to this Agreement shall not be deemed to be a waiver of any subsequent default. Waiver or breach of any provision of this Agreement shall not be deemed to be a waiver of any other or subsequent breach, and shall not be construed to be a modification of the terms of this Agreement unless this Agreement is modified as provided in paragraph 23 below.

### **18. CONFIDENTIALITY**

Contractor agrees to comply with various provisions of the federal, state, and county laws, regulations, and ordinances providing that information and records kept, maintained, or accessible by Contractor in the course of providing

services and work under this Agreement, shall be privileged, restricted, or confidential. Contractor agrees to keep confidential, all such privileged, restricted or confidential information and records obtained in the course of providing the work and services under this Agreement. Disclosure of such information or records shall be made by Contractor only with the express written consent of the County.

## 19. CONFLICTS

Contractor agrees that he/she has no interest, and shall not acquire any interest, direct or indirect, that would conflict in any manner or degree with the performance of the work and services under this Agreement. Contractor agrees to complete and file a conflict-of-interest statement.

## 20. POST-AGREEMENT COVENANT

Contractor agrees not to use any confidential, protected, or privileged information that is gained from County in the course of providing services and work under this Agreement, for any personal benefit, gain, or enhancement. Further, Contractor agrees for a period of two (2) years after the termination of this Agreement, not to seek or accept any employment with any entity, association, corporation, or person who, during the term of this Agreement, has had an adverse or conflicting interest with County, or who has been an adverse party in litigation with County, and concerning such, Contractor by virtue of this Agreement has gained access to County's confidential, privileged, protected, or proprietary information.

## 21. SEVERABILITY

If any portion of this Agreement or application thereof to any person or circumstance shall be declared invalid by a court of competent jurisdiction, or if it is found in contravention of any federal, state, or county statute, ordinance, or regulation, the remaining provisions of this Agreement, or the application thereof, shall not be invalidated thereby, and shall remain in full force and effect to the extent that the provisions of this Agreement are severable.

## 22. FUNDING LIMITATION

The ability of County to enter into this Agreement is based upon available funding from various sources. In the event that such funding fails, is reduced, or is modified, from one or more sources, County has the option to terminate, reduce, or modify this Agreement, or any of its terms within ten (10) days of notifying Contractor of the termination, reduction, or modification of available funding. Any reduction or modification of this Agreement effective pursuant to this provision must comply with the requirements of paragraph 23.

## 23. AMENDMENT

This Agreement may be modified, amended, changed, added to, or subtracted from, by the mutual consent of the Parties, if such amendment or change order is in written form, and executed with the same formalities as this Agreement or in accordance with delegated authority therefor, and attached to the original Agreement to maintain continuity.

## 24. NOTICE

Any notice, communication, amendments, additions or deletions to this Agreement, including change of address of any party during the term of this Agreement, which Contractor or County shall be required, or may desire to make, shall be in writing and may be personally served, or sent by prepaid first-class mail or email (if included below) to the respective parties as follows:

If to County:

County of Mono  
Public Works Department  
Director of Public Works  
PO Box 457

Bridgeport, CA 93517

If to Contractor:

- Click here to enter text.
- Click here to enter text.
- Click here to enter text.
- Click here to enter text.
- Click here to enter text.

**25. ENTIRE AGREEMENT**

This Agreement contains the entire agreement of the parties, and no representations, inducements, promises, or agreements otherwise between the parties not embodied herein or incorporated herein by reference, shall be of any force or effect. Further, no term or provision hereof may be changed, waived, discharged, or terminated, unless executed in writing by the parties hereto.

**IN WITNESS THEREOF, THE PARTIES HERETO HAVE SET THEIR HANDS AND SEALS THIS \_\_\_\_\_ DAY OF \_\_\_\_\_, 2019.**

**COUNTY OF MONO**

**CONTRACTOR**

By: \_\_\_\_\_

By: \_\_\_\_\_

Dated: \_\_\_\_\_

Dated: \_\_\_\_\_

Taxpayer's Identification or Social Security Number: \_\_\_\_\_

APPROVED AS TO FORM:

\_\_\_\_\_  
County Counsel

APPROVED BY RISK MANAGEMENT:

\_\_\_\_\_  
Risk Manager

**ATTACHMENT A**

**AGREEMENT BETWEEN COUNTY OF MONO AND**  
Click here to enter text. **FOR THE CONSTRUCTION OF THE**  
**MONO COUNTY CIVIC CENTER TOP LIFT ASPHALT**  
**PAVING PROJECT**

**TERM:**

**FROM:** Click here to enter text.      **TO:** Click here to enter text.

**SCOPE OF WORK:**

County has selected, and Contractor shall construct the “Base Project” and additive Alternative A.

The major work items of this the MONO COUNTY CIVIC CENTER TOP LIFT ASPHALT PAVING PROJECT, Project No. MCCC PAVING (“Project”) is to place asphalt serving the new Mono County Civic Center in Mammoth Lakes including: a top lift of asphalt on portions of Tavern Road and Thompsons Way; a parking area on the northwest of the building; a sidewalk along Tavern Road; and other items or details not mentioned above that shall be performed, placed, constructed, or installed in accordance with the Project’s Invitations for Bids and the Contract Documents, including the Project Manual, Project Plans, and the Standard Specifications (2015) and the Standard Plans (2015) issued by the California Department of Transportation, as they may have been amended for County’s use.

Tasks performed in completing the Project shall follow generally-accepted practices for the construction industry and shall meet the minimum requirements and guidelines established by federal, state, and local agencies. Work tasks shall be coordinated with County’s Department of Public Works.

Note: This Agreement and Scope of Work includes and is subject to the provisions of the Contract Documents, including Project Manual, Project Plans, and the General Prevailing Wage Rates established by the California Department of Industrial Relations in effect on the date of this Agreement, which documents are attached hereto and/or by this reference incorporated herein.

**SCHEDULE OF FEES:**

See Bid Schedule set forth in Attachment B of this Agreement and incorporated herein.

**WORK SCHEDULE:**

See Contract Documents, attached hereto and incorporated herein. Completion of site improvements shall be specified by the Department of Public Works in a Notice of Completion filed in the Office of the County Recorder.



This page intentionally left blank

**ATTACHMENT B**

**AGREEMENT BETWEEN COUNTY OF MONO AND**  
Click here to enter text. **FOR THE CONSTRUCTION OF THE MONO**  
**COUNTY CIVIC CENTER TOP LIFT ASPHALT PAVING PROJECT**

**TERM:**

**FROM:** Click here to enter text.      **TO:** Click here to enter text.

**SCHEDULE OF FEES:**

See Bid Schedule, attached hereto and incorporated herein as Attachment B2. The total project cost shall not exceed Click here to enter text. dollars (\$Click here to enter text. ), unless otherwise authorized by the County in writing prior to Contractor incurring additional expenses. Upon the County’s written approval and authorization to proceed, payment shall be made for any additional items or tasks not initially specified in Attachment A (Scope of Work) attached to the Agreement and incorporated herein.

SAMPLE

This page intentionally left blank

# EXHIBIT 1

## AGREEMENT BETWEEN COUNTY OF MONO AND [Click here to enter text.](#) FOR THE CONSTRUCTION OF THE MONO COUNTY CIVIC CENTER TOP LIFT ASPHALT PAVING PROJECT

### GENERAL CONDITIONS

#### SECTION 1. GENERAL

##### 1.1 DEFINITIONS AND TERMS.

Where the following terms are used in these General Conditions, the intent and meaning shall be interpreted as identified in the Standard Specifications and as follows:

- A. **ADMITTED SURETY INSURER (or, SURETY):** A corporate insurer or inter-insurance exchange to which the State Insurance Commissioner has issued a certificate of authority to transact surety insurance in California, as defined in Section 105 of the Insurance Code.
- B. **AWARD:** The acceptance by the County of the successful bidder's proposal.
- C. **CALENDAR DAY:** Unless otherwise specified, days or calendar days means each and every day shown on the calendar, Saturdays, Sundays, and holidays included.
- D. **CHANGE ORDER:** A written order to the Contractor covering changes in the plans, specifications, or proposal quantities and establishing the basis of payment and contract time adjustment, if any, for the work affected by such changes. The work, covered by a change order, shall be within the scope of the contract.
- E. **CONTRACT (or, CONTRACT DOCUMENTS):** The written and executed agreement between the County and the Contractor covering the work to be performed. The written agreement consists of all attachments as well as all documents incorporated by reference and shall include, but is not limited to, the agreement, performance bond, labor and materials payment bond, any required insurance certificates, the project manual, any addenda issued to bidders, and the project plans.
- F. **CONTRACTOR:** The business entity entering into a contract with the County of Mono for the performance of the work.
- G. **CONTRACT ITEM (or, PAY ITEM):** A specific unit of work for which a price is provided in the Contract.
- H. **CONTRACT TIME:** The number of calendar days or working days, for completion of the contract, including authorized time extensions. If a calendar date of completion is stated in the proposal, in lieu of a number of calendar or working days, the contract shall be completed by that date.
- I. **COUNTY:** The County of Mono, a political subdivision of the State of California.
- J. **DEPARTMENT:** The Mono County Department of Public Works, except where Department of Transportation publications and offices are cited, whereupon such citations are to remain as written and refer to the State of California, Department of Transportation.

- K. **ENGINEER:** The individual, partnership, firm, or corporation duly authorized by the County to be responsible for engineering supervision of the contract work and acting directly or through an authorized representative.
- L. **EQUIPMENT:** All machinery, together with the necessary supplies for upkeep and maintenance, and also all tools and apparatus necessary for the proper construction and acceptable completion of the work.
- M. **EXTRA WORK:** An item of work not provided for in the awarded contract as previously modified by change order or supplemental agreement, but which is found by the Engineer to be necessary to complete the work within the intended scope of the contract as previously modified.
- N. **INSPECTOR:** An authorized representative of the Engineer assigned to make all necessary inspections and/or tests of the work performed or being performed, or of the materials furnished or being furnished by the Contractor.
- O. **LABORATORY:** The laboratory or laboratories authorized by the Department to test materials and work involved in the contract.
- P. **LIQUIDATED DAMAGES:** the daily amount set forth in these General Conditions to be deducted from the contract price to cover additional costs incurred by a local agency because of the contractor's failure to complete the contract work within the number of calendar days or workdays specified.
- Q. **NOTICE TO PROCEED:** A written notice from the Department to the Contractor to begin the actual contract work on the Project. If applicable, the Notice to Proceed shall state the date on which the contract time begins.
- R. **PROJECT:** The construction, installation, placement, alteration, or repair of any improvement of any kind, which is required directly or indirectly by the contract.
- S. **SPECIFICATIONS:** A part of the contract containing the written directions and requirements for completing the contract work. Standards for specifying materials or testing which are cited in the contract specifications by reference shall have the same force and effect as if physically included in the contract.
- T. **STANDARD PLANS:** State of California Department of Transportation, 2010 edition of the Standard Plans
- U. **STANDARD SPECIFICATIONS:** State of California Department of Transportation, 2010 edition of the Standard Specifications
- V. **SUPERINTENDENT:** The Contractor's executive representative who is present on the work during progress, authorized to receive and fulfill instructions from the Engineer, and who shall supervise and direct the construction.
- W. **SURVEYOR:** The individual, partnership, firm, or corporation duly authorized by the Contractor to be responsible for verifying placement of the work and acting directly or through an authorized representative.
- X. **UNEXCUSABLE DELAY:** a delay that does not entitle the Contractor to an adjustment of the Contract Limit and does not entitle the Contractor to an adjustment of the Contract Time.
- Y. **WORK:** The construction and services required by the Contract, whether completed in whole or partially completed, and includes all labor, materials, equipment, tools, supplies, tax, transportation, and services provided or to be provided by the Contractor to fulfill Contractor's obligations. The Work may constitute the whole or a part of the Project.
- Z. **WORKING DAY:** A working day shall be any day other than a legal holiday, Saturday, or Sunday on which the normal working forces of the Contractor may proceed with regular work for at least

6 hours toward completion of the contract. Unless work is suspended for causes beyond the Contractor's control, Saturdays, Sundays, and holidays on which the Contractor's forces engage in regular work, requiring the presence of an inspector, will be considered working days.

## **1.2 ORDER OF PRECEDENCE OF DOCUMENTS.**

In the event of a conflict between the Agreement (including any attachment or exhibit thereto); the Invitation for Bids and Instructions to Bidders; the Project Plans; the Technical Specifications; the 2015 State of California, Department of Transportation, Standard Specifications and Standard Plans; and the Quality Assurance Program (QAP), the Contractor shall immediately notify the County. The County shall have the sole discretion to decide to resolve any such conflict by deciding which document or provision shall govern.

## **SECTION 2. PERFORMANCE OF WORK**

### **2.1 USE OF PREMISES, HOURS OF WORK, CONTACT INFORMATION AND PUBLIC NOTIFICATION.**

- A. Work occurring within 500 feet of a residential or commercial occupancy shall be limited to the hours between 7:00 am and 8:00 pm Monday through Saturday (Sunday operations shall be limited to hours between 9:00 am and 5:00 pm). Concrete pouring is limited to daylight hours between sunrise and sunset.
- B. Unless otherwise provided, the Contractor accepts full control of any vehicles, equipment, material, or other property delivered to the site in the performance of services and work for the Project. The Contractor is solely responsible for ensuring the security and protection of such vehicles, equipment, materials, property, and Work. The County accepts no responsibility for the security, safety, or liability of said vehicles, equipment, material, property, or work until final acceptance of the Work. The Contractor understands that the project site is a public area and, as such, there may be vandalism or obstructions, protrusions, and undesirable materials on and under the ground surface that may result in damage to the Contractor's vehicles, equipment, materials, project work, or other property.
- C. Authorized representatives or agents of the Engineer and County, state, or federal government shall have the right to enter the project site at any time during execution of the Work for any purpose that will not unreasonably interfere with the Contractor's use, including, but not limited to, the conduct of its own business, facility inspection, or inspection to ensure compliance with the terms and conditions of the Project.
- D. 24 Hour Contact Number - The Contractor shall assign a project superintendent and an assistant who have the complete authority to make decisions on behalf of the Contractor. The project superintendent or the assistant shall be at the project site at all times during the construction and shall be available and on call 24 hours a day, 7 days per week for the duration of the project. The Contractor shall provide the Engineer and the Mono County Sheriff's Department primary and secondary 24-hour mobile phone numbers for the project superintendent and the assistant. These numbers shall not automatically direct calls to a recorder or other message taking service.
- E. Advance Public Notification – At least 7 days and no more than 14 days prior to beginning any work on the project, the Contractor shall deliver written notice to all adjoining residents, businesses, tenants, to the fire department and law enforcement agency having jurisdiction over the project area, and other applicable parties listed below. Notice shall be given for general construction activity in an area as well as specific activities that will, in any way, inconvenience residents/property owners/tenants or affect their operations or access to their property. Such notices shall include the expected date for start of construction, a general description of the

construction activity to take place, expected duration, and the name, address, and contact number of the Contractor's superintendent and of the County Engineer. A follow up notice shall be distributed two days prior to the construction activity. Copies of all notices shall be provided to the Engineer for approval five working days prior to the desired distribution date.

NOTICE SHALL ADDITIONALLY BE PROVIDED TO THE FOLLOWING, OR AS FOLLOWS:

Town of Mammoth Lakes Public Works Department  
Roebbelen Construction  
Mammoth Lakes Police Department

- F. Vehicular access – Vehicular access to and from commercial and residential driveways and parking lots shall be maintained at all times, except when performing items of work that cannot be accomplished without access restriction.

## **2.2 OTHER PROJECTS.**

The Contractor is advised that other projects will be taking place at the site at the same time as this Project. The Contractor will make every effort to coordinate his work with that of other contractors.

## **2.3 PROTECTION OF PROPERTY.**

Attention is directed to Section 5-1.36, "Property and Facility Preservation," of the Standard Specifications. The Contractor shall take all reasonable precautions to preserve and protect all on-site and surrounding public and private property to prevent damage of all kinds to existing structures, signs, fences, gates, roads, drainage facilities, monitoring wells, equipment, and the environment arising from the execution of this Contract, unless otherwise called for on Project Plans or in these General Conditions. In addition, the Contractor shall be responsible for the preservation and protection of all land monuments and property markers.

In addition to its obligations pursuant to the Agreement to defend, indemnify, and hold the County harmless, the Contractor shall replace, repair, and/or be responsible for any damage or injury to property of any character during the prosecution of the Work, resulting from any act, omission, neglect, or misconduct in the Contractor's manner or method of executing the Work, or at any time due to defective work or materials, and said responsibility shall not be released until the Project is completed and accepted. Repairs or replacement required as a result of such damage shall be performed to the County's satisfaction and at no additional cost to the County.

It is the Contractor's responsibility to identify and document any property or site damage that exists prior to the start of construction. If undocumented damage is discovered by the County that could have been caused as a result of the Contractor's presence, it will be the Contractor's responsibility to repair the damage to the County's satisfaction without cost to the County. If the Contractor does not repair the damage to the County's satisfaction, the County has the right, after 48 hours of written notification, to repair the damage and charge the Contractor for all expenses associated with the repair.

The Contractor shall be responsible for the safety of all persons at or near the project site as it pertains to the Project. The Contractor shall provide signage, temporary protective fencing, or covering over any open trenching, excavation, or other hazardous situation arising from the execution of the Work, to keep out unauthorized persons, at no additional cost to the County.

### **3 ENVIRONMENTAL PROTECTION.**

The Contractor shall comply with all federal, state, and local laws and regulations controlling pollution of the environment. All necessary precautions shall be taken to prevent pollution of streams, drainage channels, lakes, ponds, and reservoirs with fuels, oils, bitumens, chemicals, or other harmful materials and to prevent pollution of the atmosphere from particulate and gaseous matter. Any fuel or lubricants stored on-site shall be in appropriate and secure containers provided with secondary containment.

#### **3.1 REMOVAL OF ASBESTOS AND HAZARDOUS SUBSTANCES.**

Should the Contractor encounter materials which the Contractor reasonably believes to be asbestos or a hazardous substance as defined in Section 25914.1 of the Health and Safety Code, and the asbestos or hazardous substance has not been rendered harmless, the Contractor may continue work in unaffected areas reasonably believed to be safe, and shall immediately cease work in the affected area and immediately report the condition to the Engineer in writing.

In accordance with Section 25914.1 et seq. of the Health and Safety Code, all such removal of asbestos or hazardous substances, including any exploratory work to identify and determine the extent of such asbestos or hazardous substance, shall be performed by a person properly licensed to perform such work and shall be performed by separate contract if the presence of asbestos or hazardous substances is not disclosed in the bid documents.

#### **3.2 ARCHAEOLOGICAL AND HISTORICAL FINDINGS.**

Should the Contractor encounter, during its operations, any building, part of a building, structure, or object which is incongruous with its surroundings, the Contractor shall immediately cease operations in that location and notify the Engineer. The Engineer will immediately investigate the Contractor's finding and will direct the Contractor either to resume its operations or to suspend operations as directed.

Should the Engineer order suspension of the Contractor's operations in order to protect an archaeological or historical finding, or order the Contractor to perform extra work, such work shall be covered by an appropriate contract modification (change order, amended or supplemental agreement).

## **SECTION 3. ACKNOWLEDGEMENTS, DISCLOSURES, CERTIFICATIONS AND AFFIDAVITS**

### **3.1 DEBARMENT AND SUSPENSION CERTIFICATION**

Contractor's signature affixed to the Agreement, shall constitute a certification under penalty of perjury under the laws of the State of California, that Contractor has complied with Title 2 CFR Part 180, "OMB Guidelines to Agencies on Government wide Debarment and Suspension (non-procurement)", which certifies that he/she or any person associated therewith in the capacity of owner, partner, director, officer, or manager, is not currently under suspension, debarment, voluntary exclusion, or determination of ineligibility by any federal agency; has not been suspended, debarred, voluntarily excluded, or determined to be of ineligible by any federal agency within the past three (3) years; does not have a proposed debarment pending; and has not been indicted, convicted, or had a civil judgment rendered against it by a court of competent jurisdiction in any matter involving fraud or official misconduct within the past three (3) years. Any exceptions to this certification must be disclosed to the County.

### **3.2 NATIONAL LABOR RELATIONS BOARD CERTIFICATION**

Contractor's signature affixed to the Agreement, shall constitute a certification under penalty of perjury under the laws of the State of California that no more than one final unappealable finding of contempt of court by a federal court has been issued against Contractor within the immediately preceding two-



year period because of Contractor's failure to comply with a court order to comply with an order of the National Labor Relations Board.

### **3.3 APPLICABILITY TO SUBCONTRACTORS**

The certification and disclosure of lobbying activities forms provided in the Project Manual and/or the Agreement shall be included in each subcontract and any lower-tier contracts exceeding \$10,000. All disclosure forms, but not certifications, shall be forwarded from tier to tier until received by the Engineer.

### **3.4 QUARTERLY DISCLOSURES**

The Contractor, subcontractors and any lower-tier contractors shall file a disclosure form at the end of each calendar quarter in which there occurs any event that requires disclosure or that materially affects the accuracy of the information contained in any disclosure form previously filed by the Contractor, subcontractor, or lower-tier contractor. An event that materially affects the accuracy of the information reported includes:

- (1) A cumulative increase of \$25,000 or more in the amount paid or expected to be paid for influencing or attempting to influence a covered federal action; or
- (2) A change in the person(s) or individual(s) influencing or attempting to influence a covered federal action; or
- (3) A change in the officer(s), employees(s), or member(s) contacted to influence or attempt to influence a covered Federal Action.

## **SECTION 4. SUBCONTRACTORS**

### **4.1 SUBCONTRACTING.**

No subcontract releases the Contractor from the contract or relieves the Contractor of its responsibility for a subcontractor's work.

If the Contractor violates Public Contract Code § 4100 et seq., the County of Mono may exercise the remedies provided under Public Contract Code § 4110 and may refer the violation to the Contractors State License Board as provided under Public Contract Code § 4111.

The Contractor shall perform work equaling at least 30 percent of the value of the original total bid with the Contractor's own employees and equipment, owned or rented, with or without operators.

Each subcontract must comply with the Agreement and all contract documents including, but not limited to insurance requirements. Subcontractor shall provide all certificates and other required documentation/proof of insurance to Contractor, and Contractor shall make such documents available to County upon its request.

Each subcontractor must have an active and valid State contractor's license with a classification appropriate for the work to be performed (Bus & Prof Code, § 7000 et seq.).

The Contractor shall submit copies of subcontracts upon request by the Engineer. Before subcontracted work starts, the Contractor shall submit a Subcontracting Request form to the Engineer. The Contractor shall not use a debarred contractor; a current list of debarred contractors is available at the Department of Industrial Relations web site at: <http://www.dir.ca.gov/dlse/debar.html>

Upon request by the Engineer, the Contractor shall immediately remove and not again use a subcontractor who fails to prosecute the Work satisfactorily.

If the work involves Federal funds, each subcontract and any lower-tier subcontract that may in turn be made shall include the "Required Contract Provisions Federal-Aid Construction Contract" located in the Federal Provisions within the Project Manual.

Payment for subcontracted work involved will be withheld from progress payments due or to become due, until correction is made. Failure to comply may result in termination of the contract.

#### **4.2 PERFORMANCE OF SUBCONTRACTORS**

The bid shall list the name and address of each subcontractor to whom the bidder proposes to subcontract portions of the work in an amount in excess of one-half of one percent of the total bid or \$10,000, whichever is greater, in accordance with the Subletting and Subcontracting Fair Practices Act, commencing with Section 4100 of the Public Contract Code. The bidder's attention is invited to other provisions of the Act related to the imposition of penalties for a failure to observe its provisions by using unauthorized subcontractors or by making unauthorized substitutions.

#### **4.3 PROMPT PROGRESS PAYMENT TO SUBCONTRACTORS.**

A prime contractor or subcontractor shall pay any subcontractor not later than 7 days from receipt of each progress payment in accordance with the provision in Section 7108.5 of the California Business and Professions Code concerning prompt payment to subcontractors. The 7 days is applicable unless a longer period is agreed to in writing. Any delay or postponement of payment over 30 days may take place only for good cause and with the County's prior written approval. Any violation of Section 7108.5 shall subject the violating contractor or subcontractor to the penalties, sanctions and other remedies of that section. This requirement shall not be construed to limit or impair any contractual, administrative, or judicial remedies otherwise available to the contractor or subcontractor in the event of a dispute involving late payment or nonpayment by the prime contractor, deficient subcontract performance or noncompliance by a subcontractor.

#### **4.4 PROMPT PAYMENT OF WITHHELD FUNDS TO SUBCONTRACTORS.**

Any retainage kept by the prime contractor or by a subcontractor must be paid in full to the earning subcontractor within 30 days after the subcontractor's work is satisfactorily completed. Any delay or postponement of payment may take place only for good cause and with the County's prior written approval. Any violation of these provisions shall subject the violating contractor or subcontractor to the penalties, sanctions, and remedies specified in Section 7108.5 of the California Business and Professions Code. This requirement shall not be construed to limit or impair any contractual, administrative or judicial remedies, otherwise available to the contractor or subcontractor in the event of a dispute involving late payment or nonpayment by the contractor, deficient subcontractor performance and/or noncompliance by a subcontractor. This clause applies to both DBE and non-DBE subcontractors.

Please refer to the Federal Provisions (for contracts involving Federal funds), attached to the Agreement for further information. Where the Federal Provisions apply, they shall supersede and replace this section 4.4 to the extent inconsistent herewith.

#### **4.5 APPALACHIAN REGIONAL DEVELOPMENT ACT OF 1965.**

This project is not funded under the Appalachian Regional Development Act of 1965, therefore, page FP-13 of the Federal Provisions (if Federal Provisions are included in the contract) does not apply to this contract.

## SECTION 5. PROJECT IMPLEMENTATION

### 5.1 PRE-CONSTRUCTION CONFERENCE.

Prior to Contractor mobilization, a pre-construction conference will be held at a location, date, and time to be determined by the County for the purpose of discussing with the Contractor the scope of work, Project Plans, Technical Specifications, Special Provisions, existing conditions, coordination with disposal site operations, equipment and material storage locations, materials testing and construction quality assurance, and all essential matters pertaining to the prosecution of and the satisfactory completion of the Project as required. The Contractor's representative at this conference shall include all major superintendents for the work and may include subcontractors.

### 5.2 PROSECUTION AND PROGRESS.

The Contractor shall submit a progress schedule for the Engineer's approval within 10 calendar days after the date of the Notice to Award. The Contractor's progress schedule, when approved by the Engineer, may be used to establish major construction operations and to check on the progress of the Work. The Contractor shall provide sufficient materials, equipment, and labor to guarantee the completion of the Project in accordance with and within the time set forth in the Contract Documents.

If, in the sole judgment of the Engineer, the Contractor falls significantly behind the submitted schedule, the Contractor shall, upon the Engineer's request, submit a revised schedule for completion of the Work within the contract time and modify its operations to provide such additional materials, equipment, and labor necessary to meet the revised schedule. Should the prosecution of the Work be discontinued for any reason, the Contractor shall notify the Engineer at least 24 hours in advance of resuming operations.

### 5.3 ORDER OF WORK.

The project site is located in a climate that can experience freezing temperatures throughout the year. While determination of the means, methods, techniques, sequences, and procedures of construction are the responsibility of the Contractor, such sequencing and procedures must bear climatic conditions in mind. Work shall be scheduled and protected such that inclement weather does not damage the Work or result in a hazardous condition.

## SECTION 6. PROJECT ADMINISTRATION

### 6.1 GENERAL.

**Changes and Extra Work:** The County may make changes within the scope of work and add extra work. The Engineer describes the changes and extra work, the payment basis, and any time adjustment in a *Change Order*. A *Change Order* is approved when the County signs the *Change Order*. Until the County approves a *Change Order*, continue to perform the work under the Contract unless the Engineer orders you to start the work described in the *Change Order* before its approval. Submit detailed cost data for a unit price adjustment for a bid item if (1) the Engineer requests the data or (2) you request a unit price adjustment resulting from a change of more than 25 percent in the bid item's quantity.

---

**Control of Work:**

Attention is directed to Section 4-1.05, "Changes and Extra Work," and applicable portions of Section 5, "Control of Work," Section 7, "Legal Relations and Responsibility to the Public," and Section 8, "Prosecution and Progress," of the Standard Specifications with respect to administration of this contract and the Project.

**6.2 OMITTED ITEMS.**

The County may, if in its best interest, omit from the Work any Contract Item. Such omission shall not invalidate any other Contract provision or requirement. Should a Contract Item be omitted or otherwise ordered to be non-performed, the Contractor shall be paid for all work performed toward completion of such an item prior to the date of the order to omit such item.

**6.3 CONTRACTOR REPRESENTATION.**

The County will not recognize any subcontractor on the work. The Contractor shall at all times when work is in progress be represented in person by either a qualified, competent Superintendent or by another designated, qualified, competent representative who is duly authorized to receive and execute orders of the Engineer. The Superintendent shall be satisfactory to the County and shall not be changed except with the express written consent of the County unless the ceases to be in its employ.

All communications given to the Superintendent or other authorized representative shall be as binding as if given to the Contractor. Important communications shall be confirmed in writing. An authorized representative of the Contractor shall be available for emergency telephone communications from the County on a 24-hour, seven days per week basis during the performance of the Work.

**6.4 CONTRACTOR PERSONNEL.**

The Contractor shall at all times enforce strict discipline and good order among its employees and shall not employ on the work any unfit person or anyone not skilled in the work assigned to him or her. The Contractor shall ensure that all workers have sufficient skill and experience necessary to properly perform the work assigned to them and that workmanship shall be of the best trade practice, regardless of the quality of materials. Workers engaged in special work or skilled work shall have sufficient experience in such work and in the operation of the equipment required to perform the work satisfactorily. The Contractor shall provide, at all times, sufficient and competent labor to carry on the work properly and ensure completion of each part in accordance with the Project Plans, these General Conditions, the Special Provisions, any QAP, and the approved schedule.

An employee of the Contractor or subcontractor who is deemed by the County to be incompetent, disorderly, or otherwise objectionable shall be promptly removed by the Contractor and not reemployed on the Work.

**6.5 METHODS AND EQUIPMENT.**

The Contractor shall, at all times, employ sufficient labor and equipment for prosecuting the Work to full completion in the manner and time required by the Contract Documents.

All equipment used on the Work shall be of sufficient size and in such mechanical condition as to meet requirements of the Work and to produce a satisfactory quality of work. Equipment used on any portion of the Work shall be such that no injury to previously completed work, adjacent property, or existing facilities will result from its use.

When the methods and equipment to be used by the Contractor in accomplishing the Work are not prescribed in the Contract Documents, the Contractor is free to use any methods or equipment that will accomplish the work in conformity with the requirements of the Contract Documents.

## **6.6 PARTIAL PAYMENTS.**

Unless otherwise agreed by the County, no partial payment will be made for any materials on hand which have been furnished but not incorporated into the work.

## **6.7 FINAL ACCEPTANCE.**

Upon due notice from the Contractor of presumptive completion of the entire Project, the Engineer and County will make an inspection. If all construction provided for and contemplated by the Contract is found to be completed in accordance with the Contract Documents, such inspection shall constitute the final inspection. The County shall notify the Contractor in writing of final acceptance as of the date of the final inspection.

If, however, the inspection discloses any work, in whole or in part, as being unsatisfactory, the County will give the Contractor the necessary instructions for correction of same and the Contractor shall immediately comply with and execute such instructions. Upon correction of the work, another inspection will be made which shall constitute the final inspection, provided the work has been satisfactorily completed. In such event, the County will make the final acceptance and notify the Contractor in writing of this acceptance as of the date of final inspection.

The completion of the contract will be accepted and Notice of Completion recorded by the County only when the entire contract is completed satisfactorily to the County.

## **6.8 CLAIMS FOR ADJUSTMENT AND DISPUTES.**

If for any reason the Contractor deems that it is due additional compensation for work or materials not clearly provided for in the Contract Documents or previously authorized as extra work, the Contractor shall notify the County in writing of its intention to claim such additional compensation 24 hours before beginning the work on which the claim is based. If such notification is not given or the County is not afforded a proper opportunity by the Contractor to keep strict account of actual cost as required, then the Contractor hereby agrees to waive any claim for such additional compensation. Such notice by the Contractor and the fact that the Engineer has kept account of the cost of the work shall not in any way be construed as proving or substantiating the validity of the claim. When the work on which the claim for additional compensation is based has been completed, the Contractor shall, within 14 calendar days, submit its written claim to the County for consideration in accordance with local laws or ordinances. Nothing in this subsection shall be construed as a waiver of the Contractor's right to dispute final payment based on differences in measurements or computations.

Claims falling within the provisions of California Public Contract Code section 9204 shall be processed in accordance with that section.

## **6.9 FORCE MAJEURE.**

Except for defaults of subcontractors at any tier, the Contractor shall not be liable for any excess costs if the failure to perform the Contract arises from causes beyond the control and without the fault or negligence of the Contractor. Examples of such causes include, but are not limited to:

- a) Acts of God or of the public enemy, and
- b) Acts of the federal or State government in either its sovereign or contractual capacity.

If the failure to perform is caused by the default of a subcontractor at any tier, and if the cause of the default is beyond the control of both the Contractor and subcontractor, and without the fault or negligence of either, the Contractor shall not be liable for any excess costs for failure to perform.

## **6.10 WARRANTY AND GUARANTEE.**

The Contractor warrants to the County that all materials furnished under this Contract shall be new unless otherwise specified and that all Work, including without limitation all materials, will be of good quality, free from faults and defects and in conformance with contract requirements. Any work not so conforming to these standards may be considered defective. The obligations of the Contractor in this subsection shall be in addition to, and not in limitation of, any obligations imposed upon it by those guarantees required by the contract or otherwise prescribed by law.

Neither the recordation of a Notice of Completion, nor the final certification or payment, nor any provision of the Contract or partial or entire use or occupancy of the premises by the County shall constitute an acceptance of the Work not performed in accordance with the Contract or relieve the Contractor of liability with respect to any express warranties or responsibility for faulty materials or workmanship.

The Contractor agrees that all work and materials provided under this contract are guaranteed for a period of one year against defects of any kind or nature and that any defective work or materials resulting from the Contractor's negligence will be repaired or replaced by the Contractor at its own expense immediately upon notification by the County. The Contractor shall furnish a warranty bond in the amount of 10 percent of the contract price as provided for and meeting the requirements specified in the Agreement. The warranty bond shall be furnished and approved prior to final payment and release and shall remain in effect for the duration of the guarantee period to insure the repair or replacement of defective work or materials. The one-year guarantee period shall commence on the day of recordation of the Notice of Completion.

The County will give notice of observed defects with reasonable promptness. The County is authorized to make such repairs and charge the Contractor the actual costs of such necessary labor and material, if, within 14 calendar days after mailing a notice in writing to the Contractor or its agent, the Contractor neglects to make or undertake with due diligence the aforesaid repairs; provided, however, that in the case of an emergency where, in the opinion of the County, delay would cause hazard to health or serious loss or damage, repairs may be made without notice being sent to the Contractor, and the Contractor shall pay the cost thereof.

If after installation and acceptance, the Work provided for under this Contract proves to be unsatisfactory to the County, the County shall have the right to use the Work until it can, without damage to the County, be taken out of service for correction or replacement. Such period of use of the defective Work pending correction or replacement shall in no way decrease the guarantee period.

Nothing in this section shall be construed to limit, relieve or release the Contractor's, subcontractor's, and supplier's liability to the County for damages sustained as the result of latent defects in the Work caused by the negligence of their respective agents, employees or subcontractors.

## **SECTION 7: TERMINATION**

### **7.1 TERMINATION BY CONTRACTOR.**

The Contractor shall have the right to terminate the Contract only upon the occurrence of one of the following:

1. Provided that County has not commenced reasonable action to remove any order of a court within the 90 day period, the Work is stopped for 90 consecutive days, through no act or fault of Contractor, any Subcontractor, or any employee or agent of Contractor or any Subcontractor, due to an issuance of an order of a court or other public authority having jurisdiction or due to an act of government, such as a declaration of a national emergency

making material unavailable.

2. The County fails to perform any material obligation under the Contract Documents and fails to cure such default within 30 days, or County has not commenced to cure such default within 30 days where such cure will require a reasonable period beyond 30 days and diligently prosecutes the same to completion, after receipt of notice from Contractor stating the nature of such default(s).

Upon occurrence of one of the events listed above, the Contractor may, upon 10 days additional notice to County and Engineer, and provided that the condition giving rise to Contractor's right to terminate is continuing, terminate the Contract.

Upon termination by Contractor, County will pay to Contractor the sum determined by Section 7.4 of these General Conditions. Such payment will be the sole and exclusive remedy to which Contractor is entitled in the event of termination of the Contract by Contractor pursuant to this section; and Contractor will be entitled to no other compensation or damages and expressly waives the same.

## **7.2 TERMINATION BY COUNTY FOR CAUSE.**

The County will have the right to terminate the Contract for cause or the Contractor's right to perform the Contract for cause at any time after the occurrence of any of the following events:

1. Contractor becomes insolvent or files for relief under the bankruptcy laws of the United States.
2. Contractor makes a general assignment for the benefit of its creditors or fails to pay its debts as the same become due.
3. A receiver is appointed to take charge of Contractor's property.
4. The commencement or completion of any Work activity on the critical path is more than 6 days behind the date set forth in the Contract Schedule for such Work activity as a result of an Unexcusable Delay.
5. Contractor abandons the Work.

Upon the occurrence of any of the following events and subject to the clause entitled "Force Majeure", the County will have the right to terminate the Contract for cause or the Contractor's right to perform the Contract for cause if the Contractor fails to promptly commence to cure such default and diligently prosecute such cure within 5 days after notice from the County, or within such longer period of time as is reasonably necessary to complete such cure:

1. Contractor persistently or repeatedly refuses or fails to supply skilled supervisory personnel, an adequate number of properly skilled workers, proper materials, or necessary equipment to prosecute the Work in accordance with the Contract Documents.
2. Contractor fails to make prompt payment of amounts properly due subcontractors after receiving payment from County.
3. Contractor fails to follow applicable legal requirements.
4. Contractor persistently or materially fails to execute the Work in accordance with the Contract Documents.
5. Contractor is in default of any other material obligation under the Contract Documents.
6. Contractor persistently or materially fails to comply with applicable safety requirements.

Upon any of the occurrences referred to above the County may, at its election and by notice to the Contractor, terminate the Contract and take possession of the Project site and all materials, supplies, equipment, tools, and construction equipment and machinery thereon owned by Contractor; accept the assignment of any or all of the subcontracts; and then complete the Work by any method County may deem expedient. If requested by County, Contractor shall remove any part or all of Contractor's materials, supplies, equipment, tools, and construction equipment and machinery from the Project site within 7 days of such request; and if Contractor fails to do so, County may remove or store, and after 90 days sell, any of the same at Contractor's expense.

If the Contract or Contractor's right to perform is terminated by the County as provided in this section, the Contractor shall not be entitled to receive any further payment until the expiration of 35 days after Final Completion and acceptance of all Work by County.

If the unpaid balance of the Contract Sum exceeds the cost of completing the Work, including all additional costs and expenses made necessary thereby, including costs for County staff time, plus all losses sustained, including any liquidated damages provided under the Contract Documents, such excess shall be paid to Contractor. If such costs, expenses, losses, and liquidated damages exceed the unpaid balance of the Contract Sum, Contractor shall pay such excess to County.

No termination or action taken by the County after termination shall prejudice any other rights or remedies of the County provided by law or by the Contract Documents upon such termination; and the County may proceed against the Contractor to recover all losses suffered by County.

Termination of the Contract does not relieve the surety of its obligation for any just claims arising out of the work performed.

### **7.3 TERMINATION BY COUNTY FOR CONVENIENCE.**

The County may, at its option, terminate this Contract, in whole or from time to time in part, at any time by giving notice to Contractor. Upon such termination, the Contractor agrees to waive any claims for damages, including loss of anticipated profits, on account thereof; and, as the sole right and remedy of the Contractor, the County shall pay the Contractor in accordance with this Section, below.

Upon receipt of notice of termination under this Section 7.3, Contractor shall, unless the notice directs otherwise, do the following:

1. Immediately discontinue the Work to the extent specified in the notice.
2. Place no further orders or subcontracts for materials, equipment, services, or facilities, except as may be necessary for completion of such portion of the Work as is not discontinued.
3. Promptly cancel, on the most favorable terms reasonably possible, all subcontracts to the extent they relate to the performance of the discontinued portion of the Work.
4. Thereafter, do only such Work as may be necessary to preserve and protect Work already in progress and to protect materials, plants, and equipment on the Project site or in transit thereto.

Upon such termination, the obligations of the Contract shall be as set forth in section 7.4. Termination of the Contract does not relieve the surety of its obligation for any just claims arising out of the work performed.



---

**7.4 PAYMENT ADJUSTMENT FOR TERMINATION.**

Section 8-1.14E, "Payment Adjustment for Termination," of the Standard Specifications is replaced in its entirety by the following language:

"Upon such termination, the County shall pay to Contractor the sum of the following:

1. The amount of the Contract Sum allocable to the portion of the Work properly performed by Contractor as of the date of termination, less sums previously paid to Contractor.
2. Plus previously unpaid costs of any items delivered to the Project Site that were fabricated for subsequent incorporation in the Work.
3. Plus any proven losses with respect to materials and equipment directly resulting from such termination.
4. Plus reasonable demobilization costs.
5. Plus reasonable costs of preparing a statement of the aforesaid costs, expenses, and losses in connection with such termination.

The above payment shall be the sole and exclusive remedy to which the Contractor is entitled in the event of termination of the Contract by the County pursuant to Sections 7.2 or 7.3; and the Contractor will be entitled to no other compensation or damages and expressly waives same."

**SECTION 8. MATERIALS****8.1 MANUFACTURER'S SPECIFICATIONS AND RECOMMENDATIONS.**

Wherever, in the Contract Documents, a particular brand or make of item is specified, the Contractor shall comply strictly with the specifications and recommendations of that manufacturer as to the installation and/or application of that particular item. This requirement shall be met with respect to the specifications and recommendations of the manufacturer of an "or equal" item approved by the Engineer and installed or applied by Contractor.

**8.2 REFERENCE TO SPECIFICATIONS AND TRADE NAMES.**

Where American Society for Testing Materials (ASTM) or other specifications or standards are mentioned, it shall be understood that the materials or methods mentioned therewith shall conform to all requirements of the same that are in effect on the date of bid submission.

Where the trade name of a product or the name of a product or the name of a manufacturer appears, it shall be understood to specify the product so identified or its "Approved Equal." The words "Or Equal" or "Approved Equal" shall mean equal in the opinion of, and approval by, the Engineer. Any substitutions for products or manufacturers mentioned in the Contract Documents shall be submitted by the Contractor to the County for approval within 14 calendar days following the Award of Contract or as otherwise permitted in writing by the Engineer.

**8.3 STORAGE OF MATERIALS.**

Materials shall be stored as to assure the preservation of their quality and fitness for the Work. Stored materials, even if approved before storage, may again be inspected prior to their use in the Work. Stored materials shall be located so as to facilitate their prompt inspection. The Contractor shall coordinate the storage of all materials with the County and the location of the Contractor's plant and parked equipment or vehicles shall be as directed by the County. Private property shall not be used for storage purposes

without written permission of the owner or lessee of the property. The Contractor shall make all arrangements and bear all expenses for the storage of materials on private property. Upon request, the Contractor shall furnish the County a copy of the owner's or lessee's permission. All storage sites on private or County property shall be restored to their original condition by the Contractor at its entire expense, except as otherwise agreed to in writing by the County.

## **SECTION 9. CONSTRUCTION DETAILS**

### **9.1 ORDER OF WORK.**

The location where Project improvements are to be constructed will be exposed to public traffic. The Contractor shall conduct operations so that conditions do not exist that would create a nuisance, hazard, or other damage. Appropriate safety measures, warning devices and protective devices shall be implemented to protect all workers, the traveling public, and the work.

### **9.2 SANITARY, HEALTH, AND SAFETY PROVISIONS.**

The Contractor shall provide and maintain in a neat, sanitary condition such accommodations for the use of its employees as may be necessary to comply with the requirements of the State and local Health Department, or of other bodies or tribunals having jurisdiction.

Attention is directed to federal, State, and local laws, rules and regulations concerning construction safety and health standards. The Contractor shall not require any worker to work in surroundings or under conditions that are unsanitary, hazardous, or dangerous to that worker's health or safety.

The Engineer and County shall have **NO** responsibility for job site safety. The Contractor and his subcontractors must execute their daily work in accordance with the latest edition of the Occupational Safety and Health Administration (OSHA).

### **9.3 CONSTRUCTION SITE NUISANCE.**

The Contractor shall maintain preventative controls of blowing dust, noise, and other nuisances from construction work. No dogs or other animals are allowed within the project limits.

### **9.4 PUBLIC CONVENIENCE AND SAFETY.**

The Contractor shall provide temporary protective fencing, barriers, and/or covering over any open trenching or excavation arising from the execution of this Contract, to keep out unauthorized persons, at no additional cost to the County. The cost for providing signage, barriers, or any other items associated with public convenience and safety shall be the sole responsibility of the Contractor and no additional payment will be allowed therefor.

Contractor shall comply with OSHA regulations applicable to Contractor regarding necessary safety equipment and procedures. Contractor shall comply with safety instructions issued by County. Contractor's personnel shall wear hard hats and safety vests at all times while working at the project site. Pursuant to the authority contained in Section 591 of the Vehicle Code, County has determined that such areas are within the limits of the project and are open to public traffic. Contractor shall comply with all applicable requirements set forth in Divisions 11, 12, 13, 14, and 15 of the Vehicle Code. Contractor shall take all reasonably necessary precautions for safe operation of its vehicles and the protection of the traveling public from injury and damage from such vehicles. All subcontracts entered into by Contractor shall contain the above provisions.

---

**9.5 HIGHWAY CONSTRUCTION EQUIPMENT.**

Attention is directed to Section 591 of the Vehicle Code and Sections 7-I.01D, "Vehicle Code," and 5-1.37B, "Load Limits," of the Standard Specifications. The Contractor shall take all necessary precautions for safe operation of its equipment and the protection of the public from injury and damage from such equipment.

**9.6 PERMITS.**

The Contractor shall give all notices as required and comply with all laws, ordinances, rules and regulations bearing on the conduct of the Work as drawn and specified. If the Contractor observes that the Project Plans and Technical Specifications are at variance therewith, the Contractor shall notify the County promptly in writing, of any necessary changes in the work. If the Contractor performs any work knowing it to be contrary to such laws, ordinances, rules and regulations, and without such notice to the County, the Contractor shall bear all costs arising therefrom. Copies of permits shall be furnished to the County.

**9.7 CONSTRUCTION LAYOUT AND STAKES.**

The Contractor shall engage the services of a State of California licensed Professional Land Surveyor to perform construction layout. All staking on the project shall be performed by, or under, the direct supervision of a Professional Land Surveyor. The Contractor will be responsible for establishing and maintaining all survey controls and other layout that may be required for construction of the work.

**9.8 TESTING AND INSPECTIONS.**

Aside from materials testing and certifications required from the Contractor in the Quality Assurance Program (QAP), Technical Specifications, Standard Specifications, Special Provisions (if applicable) and/or these General Conditions, the County will provide testing services for installed work. Inspections shall be performed either: (1) as directed by the Engineer; or (2) pursuant to a written Inspection plan provided by County.

**9.9 CONTRACTOR QUALITY CONTROL.**

The Contractor shall be responsible for the quality of all materials entering into the work and of the work performed. The County and Engineer shall establish, maintain, and modify if needed, a quality control system that will provide assurance that materials and completed work conform to contract requirements. Where applicable, a copy of the QAP, which establishes testing frequency for materials incorporated into the work and criteria used to monitor the Contractor's conformance with Project Plans and Technical Specifications, will be included in the Project Manual.

**9.10 INSPECTION OF THE WORK.**

All materials and each part or detail of the work shall be subject to inspection by the Engineer. The Engineer shall be allowed access to all parts of the work and shall be furnished with such information and assistance by the Contractor as is required to make a complete and detailed inspection.

If the Engineer requests it, the Contractor, at any time before acceptance of the work, shall remove or uncover such portions of the finished work as may be directed. After examination, the Contractor shall restore said portions of the work to the standard required by the specifications. Should the work thus exposed or examined prove acceptable, the uncovering, or removing, and the replacing of the covering or making good of the parts removed will be paid for as extra work; but should the work so exposed or examined prove unacceptable, the uncovering, or removing, and the replacing of the covering or making good of the parts removed will be at the Contractor's expense.

Any work done or materials used without supervision or inspection by an authorized representative of the County may be ordered removed and replaced at the Contractor's expense unless the County's

representative failed to inspect after having been given reasonable notice in writing that the work was to be performed.

### **9.11 RETEST OF WORK.**

When, as provided for in the Contract Documents, the County or Contractor performs sampling and test of the work and the tests show a failure to meet the requirements of the Special Provisions, the QAP, Technical Specifications, or Standard Specifications, the expense of re-testing, after re-working or substitution by the Contractor, will be at the expense of the Contractor, and such costs will be deducted from any amounts due to the Contractor.

### **9.12 MAINTENANCE DURING CONSTRUCTION.**

The Contractor shall maintain the Work during construction and until the Work is accepted. This maintenance shall constitute continuous and effective Work prosecuted day by day, with adequate equipment and forces so that the work is maintained in satisfactory condition at all times. All costs of maintenance work before the project is accepted shall be included in the unit prices bid on the various Contract Items, and the Contractor will not be paid an additional amount for such work.

Should the Contractor at any time fail to maintain the work as provided herein, the Engineer shall immediately notify the Contractor of such noncompliance. Such notification shall specify a reasonable time within which the Contractor shall be required to remedy such unsatisfactory maintenance condition. The time specified will give due consideration to the exigency that exists. Should the Contractor fail to respond to the Engineer's notification, the Engineer may suspend any work necessary for the County to correct such unsatisfactory maintenance condition, depending on the exigency that exists. Any maintenance cost incurred by the County shall be deducted from monies due or to become due the Contractor.

## **SECTION 10. OPERATIONS AND SAFETY**

### **10.1 TEMPORARY CONTRACTOR FACILITIES.**

At a minimum, the Contractor shall provide chemical toilets for use by contractor and subcontractor employees. Chemical toilets shall be regularly serviced to maintain a clean and odorless facility.

The Contractor's storage area shall be determined at the pre-construction conference. The Contractor shall secure at his own expense any area required for storage of equipment or materials, or for other supplies.

The County will not be responsible for providing telephone, electrical, water, sewer, or any other temporary utility for use by the Contractor.

The Contractor shall remove all equipment, materials, and rubbish from the work areas which it occupies and shall leave the areas in a clean, safe and presentable condition.

### **10.2 BORROW, DISPOSAL AND MATERIAL SITES.**

The operation of any borrow or disposal sites used by the Contractor to produce or dispose of materials for this project shall comply with the requirements of the contract documents. All provisions for water pollution, air pollution, and sound control that apply within the limits of the contract shall apply to all borrow or disposal sites utilized by the Contractor.

Full compensation for complying with the requirements for borrow, disposal and material sites in this section shall be considered as included in the contract prices paid for the items of work which require the use of the sites and no additional compensation will be allowed therefor.

### **10.3 WATER SUPPLY.**

The Contractor is responsible for making its own arrangements to obtain an adequate supply of water required for the proper construction of this project in accordance with the contract documents. The Contractor shall be responsible for all costs associated with obtaining construction water. If the Contractor uses non-potable water on the project, the sources and discharge of non-potable water shall meet the California Department of Health Services water reclamation criteria and the requirements of the Lahontan Regional Water Quality Control Board.

If used, non-potable water shall not be conveyed in tanks or drain pipes which will be used to convey potable water. There shall be no connection between non-potable water supplies and potable water supplies. Non-potable water supply, tanks, pipes, and other conveyances of non-potable water shall be labeled, "NON-POTABLE WATER—DO NOT DRINK."

Full compensation for developing a water supply, loading, and transporting water, labeling as specified, and dust control and moisture-conditioning on the project site shall be considered included in the prices paid for the various Contract Items of work involving the use of water and no additional compensation will be allowed therefor.

The Contractor shall, whenever possible and not in conflict with the above requirements, minimize the use of water during construction of the project. Watering equipment shall be kept in good working order; water leaks shall be repaired promptly; and washing of equipment, except when necessary for safety or for the protection of equipment, shall be discouraged.

When ordered by the Engineer, a dust palliative conforming to the provisions of Section 18, "Dust Palliative," of the Standard Specifications shall be used to control dust on this project. No direct payment shall be made for dust palliative. Payment for dust palliative shall be included in the cost of other work.

### **10.4 EXISTING FACILITIES.**

The Contractor shall be responsible for protecting all existing structures and facilities from damage as a result of the Contractor's activities. Any damage resulting from the Contractor's operations shall be repaired immediately, at the Contractor's expense.

## **SECTION 11. PROGRESS MEETINGS**

### **11.1 WEEKLY PROGRESS MEETINGS.**

The Engineer will conduct Progress Meetings at regularly scheduled times convenient for all parties involved. Progress Meetings are in addition to specific meetings held for other purposes, such as coordination meetings. Discussions will address administrative and technical issues of concern, determining resolutions, and development of deadlines for resolution within allowable timeframes.

### **11.2 ATTENDEES.**

As may be required by the Engineer, in addition to representatives of Mono County and the Contractor, each subcontractor, supplier or other entity concerned with current progress or involved in planning, coordination or performance of future activities shall be represented at these meetings by individuals directly involved with the Contract and authorized to conclude matters relating to progress.

## SECTION 14. WORK SCHEDULE AND LIQUIDATED DAMAGES

### 14.1 BEGINNING OF WORK AND TIME OF COMPLETION.

The Contractor shall begin work on the date provided in the Notice to Proceed issued by the Public Works Director or his designee. The work shall be diligently prosecuted to completion before May 15, 2020.

### 14.2 LIQUIDATED DAMAGES.

The County expects the Contractor to perform its responsibilities and tasks as specified in these Contract Documents. The expectation is reasonable, within normally acceptable business practices, and in the best interest of the County and its residents. The Contractor acknowledges that the County, in entering this Agreement, has considered and relied on the Contractor's representations as to its ability and commitment to quality and timeliness of service; that the provision of reliable and timely services is of utmost importance to the County; and that the County will suffer damages if the Contractor fails to fulfill its obligations under the Contract. The Contractor acknowledges that it is and will be impractical and extremely difficult to ascertain and determine the exact amount of damages that the County will suffer and that liquidated or actual damages attach and will be payable from any funds due to the Contractor.

The liquidated damages described below, represent the projected financial loss and expenditures that may occur as a result of Contractor non-performance, including financial loss as a result of project delays. The County and Contractor agree that the liquidated damages provided for herein do not represent a penalty; rather, the liquidated damages represent a good faith effort by the County and Contractor to establish a reasonable estimate of the damages that will be incurred by the County in the circumstances described, considering all of the circumstances existing on the date of contract award, including the relationship of the sums to the range of harm to the County that reasonably could be anticipated and the anticipation that proof of actual damages would be costly or inconvenient.

This provision for liquidated damages for delay shall in no manner affect the County's right to terminate the Contract or the Contractor's right to perform the Contract as provided elsewhere in the Contract Documents. The County's exercise of the right to terminate shall not release the Contractor from its obligation to pay said liquidated damages in the amount set out below.

The Contractor shall pay to the County the sum of **\$19,000.00 per day**, as liquidated damages, for each and every working day's delay in finishing the work in excess of the number of working days prescribed above. This sum is based on the recommended calculation located in the Caltrans Local Assistance Procedures Manual at page 17-18 available at:

<http://www.dot.ca.gov/hq/LocalPrograms/lam/LAPM/ch12.pdf>

### 14.3 BREACH.

If conditions of non-performance justifying the imposition of liquidated damages continue, they may amount to a material breach for which the County may pursue recovery of actual losses resulting from the Contractor's failure to perform, and the County expressly reserves this right. The County shall notify the Contractor in writing, for any default specified herein, and such liquidated damages shall be paid by the Contractor within thirty (30) calendar days of the County's notice. The Contractor's failure to pay the assessed liquidated damages within the designated time-frame may be deemed by the County as a breach of contract.

---

**SECTION 15. PROJECT CLOSEOUT****15.1 “As-Built” Drawings.**

The Contractor shall maintain a set of accurate “as-built” drawings during the course of the project. Any project work completed that varies from the “as-built” drawings as issued shall be legibly noted on the “as-built” drawings in red ink. Both text and line work shall be used to reflect the changes. The “as-built” drawings shall be clearly labeled as “as-built” drawings and each sheet signed and dated by the Contractor, certifying that the information provided is accurate. At the completion of the project and prior to final payment, the “as-built” drawings shall be delivered to the County and, upon receipt, shall be maintained as the property of the County.

## EXHIBIT 2

**AGREEMENT BETWEEN COUNTY OF MONO AND**  
**Click here to enter text. FOR THE CONSTRUCTION OF THE**  
**MONO COUNTY CIVIC CENTER TOP LIFT ASPHALT PAVING**  
**PROJECT**

**PREVAILING WAGES AS OF: \_\_\_\_\_ [DATE]**

A. Determination.

The services and work to be provided by Contractor under this Agreement constitute a public work within the meaning of California Labor Code sections 1720 and 1720.3. Accordingly, and as required by California Labor Code section 1771, Contractor and any subcontractor under him, shall pay not less than the general prevailing rate of per diem wages, and not less than the general prevailing rate of per diem wages for holiday and overtime work, to all workers employed in the execution of those services and work requested by the County as described in Attachment A (Scope of Work) of this Agreement that constitute a public work.

B. Prevailing Wage Rate.

The general prevailing rate of per diem wages applicable to each class of worker employed in the execution of those services and work that constitute a public work under this Agreement has been determined by the Director of the California Department of Industrial Relations (hereinafter referred to as "Director"). Pursuant to California Labor Code section 1773.2, copies of the Director's determination are on file at the Mono County Department of Public Works office, 74 North School Street, Bridgeport, California, and are available to any interested party upon request.

C. Apprentices.

Pursuant to California Labor Code section 1777.5, properly registered apprentices performing services and work that constitute a public work, if any, shall be paid the standard wage paid to apprentices under the regulations of the craft or trade at which he or she is employed, and shall be employed only at the work of the craft or trade to which he or she is registered. In addition, Contractor and/or any subcontractor under him employing a registered apprentice to perform services or work that constitute a public work shall comply with the remaining requirements and provisions of California Labor Code section 1777.5, a copy of which is included at the end of this Exhibit 2. The Contractor, as the prime contractor under any contract issued for the 2018 MONO COUNTY FOG SEAL AND STRIPING PROJECT, shall be responsible for complying with California Labor Code section 1777.5 for all apprenticeable positions and workers employed by the Contractor.

D. Penalty for Non-Payment of Prevailing Wages.

Pursuant to California Labor Code section 1775, Contractor, and any subcontractor under him, shall, as a penalty to the County, forfeit not more than Two Hundred dollars (\$200.00) for each calendar day, or portion thereof, for each worker paid less than the general rate of per diem wages for the performance of services and work that constitute a public work, as determined by the Director, for the work or craft for which the worker is employed in the performance of services and work provided under this Agreement that constitute a public work, except as provided by California Labor Code section 1775(b). In addition, Contractor and/or any subcontractor under him shall comply with and be subject to the remaining requirements and provisions of California Labor Code section 1775, a copy of which is included at the end of this Exhibit 2.



E. Payroll Records.

Pursuant to California Labor Code section 1776, Contractor, and any subcontractor under him, shall keep accurate payroll records, showing the name, address, social security number, work classification, straight time and overtime hours worked each day and week and the actual per diem wages paid to each journeyman, apprentice, worker, or other employee employed by him or her in connection with the performance of the services and work requested by the County, as described in Attachment A (Scope of Work) of this Agreement.

F. Inspection of Payroll Records.

Contractor, and any subcontractor under him, shall comply with each of the additional requirements set forth in California Labor Code section 1776, regarding: (1) the form of records; (2) the provision of records upon request to the County, the Division of Labor Standards Enforcement, and the Division of Apprenticeship Standards of the California Department of Industrial Relations; and, (3) the inspection of records by the public.

G. Posting of Prevailing Wages at Job Site.

Pursuant to California Labor Code section 1773.2, Contractor shall post at each job site in connection with this Agreement a copy of the Director's determination of the general prevailing rate of per diem wages for each classification of worker required in the execution of those services and work requested by the County, as described in Attachment A (Scope of Work) of this Agreement that constitute a public work.

H. Hours.

Pursuant to California Labor Code section 1810, the time of service of any worker employed by Contractor, or by any subcontractor under him, in the performance of services and work requested by the County, as described in Attachment A (Scope of Work) of this Agreement that constitute a public work, is limited and restricted to eight (8) hours during any one (1) calendar day and 40 hours during any one (1) calendar week, except as otherwise provided by the California Labor Code.

I. Overtime.

Pursuant to California Labor Code section 1815, the performance of services and work, as described in Attachment A (Scope of Work) of this Agreement that constitute a public work by employees of Contractor, or employees of any subcontractor under him, in excess of eight hours per calendar day, and 40 hours during any one week, shall be permitted upon compensation for all hours worked in excess of eight hours per calendar day at not less than one and one-half (1½) times the basic rate of pay.

J. Records of Hours.

Contractor, and any subcontractors under him, shall keep an accurate record showing the name of and actual hours worked each calendar day and each calendar week by each worker employed by him or her in connection with the performance of the services and work requested by the County that constitute a public work, as described in Attachment A (Scope of Work) of this Agreement. The record shall be kept open at all reasonable hours to the inspection of the County and to the Division of Labor Standards Enforcement as required by California Labor Code section 1812.

K. Penalty for Violation of Work Hours.

Pursuant to California Labor Code section 1813, Contractor, and any subcontractor under him, shall, as a penalty to the County, forfeit twenty-five dollars (\$25.00) for each worker employed by the respective contractor or subcontractor in the execution of the services and work requested by the County that constitute a public work, as described in Attachment A (Scope of Work) of this Agreement,

for each calendar day during which the worker is required or permitted to work more than eight (8) hours in any one (1) calendar day and 40 hours in any one calendar week.

L. Registration with DIR and Compliance Monitoring.

Pursuant to California Labor Code section 1725.5, unless subject to the limited exceptions stated in Labor Code section 1771.1, no contractor or subcontractor may be qualified or listed in a bid proposal or awarded a contract for a public works project unless registered with the Department of Industrial Relations. This project is subject to compliance monitoring and enforcement by the Department of Industrial Relations.

## CALIFORNIA LABOR CODE SECTIONS

### California Labor Code Section 1775:

(a) (1) The contractor and any subcontractor under the contractor shall, as a penalty to the state or political subdivision on whose behalf the contract is made or awarded, forfeit not more than two hundred dollars (\$200) for each calendar day, or portion thereof, for each worker paid less than the prevailing wage rates as determined by the director for the work or craft in which the worker is employed for any public work done under the contract by the contractor or, except as provided in subdivision (b), by any subcontractor under the contractor.

(2) (A) The amount of the penalty shall be determined by the Labor Commissioner based on consideration of both of the following:

(i) Whether the failure of the contractor or subcontractor to pay the correct rate of per diem wages was a good faith mistake and, if so, the error was promptly and voluntarily corrected when brought to the attention of the contractor or subcontractor.

(ii) Whether the contractor or subcontractor has a prior record of failing to meet its prevailing wage obligations.

(B) (i) The penalty may not be less than forty dollars (\$40) for each calendar day, or portion thereof, for each worker paid less than the prevailing wage rate, unless the failure of the contractor or subcontractor to pay the correct rate of per diem wages was a good faith mistake and, if so, the error was promptly and voluntarily corrected when brought to the attention of the contractor or subcontractor.

(ii) The penalty may not be less than eighty dollars (\$80) for each calendar day, or portion thereof, for each worker paid less than the prevailing wage rate, if the contractor or subcontractor has been assessed penalties within the previous three years for failing to meet its prevailing wage obligations on a separate contract, unless those penalties were subsequently withdrawn or overturned.

(iii) The penalty may not be less than one hundred twenty dollars (\$120) for each calendar day, or portion thereof, for each worker paid less than the prevailing wage rate, if the Labor Commissioner determines that the violation was willful, as defined in subdivision (c) of Section

1777.1.

(C) If the amount due under this section is collected from the contractor or subcontractor, any outstanding wage claim under Chapter 1 (commencing with Section 1720) of Part 7 of Division 2 against that contractor or subcontractor shall be satisfied before applying that amount to the penalty imposed on that contractor or subcontractor pursuant to this section.

(D) The determination of the Labor Commissioner as to the amount of the penalty shall be reviewable only for abuse of discretion.

(E) The difference between the prevailing wage rates and the amount paid to each worker for each calendar day or portion thereof for which each worker was paid less than the prevailing wage rate shall be paid to each worker by the contractor or subcontractor, and the body awarding the contract shall cause to be inserted in the contract a stipulation that this section will be complied with.

(b) If a worker employed by a subcontractor on a public works project is not paid the general prevailing rate of per diem wages by the subcontractor, the prime contractor of the project is not liable for any penalties under subdivision (a) unless the prime contractor had knowledge of that failure of the subcontractor to pay the specified prevailing rate of wages to those workers or unless the prime contractor fails to comply with all of the following requirements:

(1) The contract executed between the contractor and the subcontractor for the performance of work on the public works project shall include a copy of the provisions of this section and Sections 1771, 1776, 1777.5, 1813, and 1815.

(2) The contractor shall monitor the payment of the specified general prevailing rate of per diem wages by the subcontractor to the employees, by periodic review of the certified payroll records of the subcontractor.

(3) Upon becoming aware of the failure of the subcontractor to pay his or her workers the specified prevailing rate of wages, the contractor shall diligently take corrective action to halt or rectify the failure, including, but not limited to, retaining sufficient funds due the subcontractor for work performed on the public works project.

(4) Prior to making final payment to the subcontractor for work performed on the public works project, the contractor shall obtain an affidavit signed under penalty of perjury from the subcontractor that the subcontractor has paid the specified general prevailing rate of per diem wages to his or her employees on the public works project and any amounts due pursuant to Section 1813.

(c) The Division of Labor Standards Enforcement shall notify the contractor on a public works project within 15 days of the receipt by the Division of Labor Standards Enforcement of a complaint of the failure of a subcontractor on that public works project to pay workers the general prevailing rate of per diem wages.

California Labor Code Section 1777.5:

(a) This chapter does not prevent the employment of properly registered apprentices upon public works.

(b) (1) Every apprentice employed upon public works shall be paid the prevailing rate of per diem wages for apprentices in the trade to which he or she is registered and shall be employed only at the work of the craft or trade to which he or she is registered.

(2) Unless otherwise provided by a collective bargaining agreement, when a contractor requests the dispatch of an apprentice pursuant to this section to perform work on a public works project and requires the apprentice to fill out an application or undergo testing, training, an examination, or other preemployment process as a condition of employment, the apprentice shall be paid for the time spent on the required preemployment activity, including travel time to and from the required activity, if any, at the prevailing rate of per diem wages for apprentices in the trade to which he or she is registered. Unless otherwise provided by a collective bargaining agreement, a contractor is not required to compensate an apprentice for the time spent on preemployment activities if the apprentice is required to take a preemployment drug or alcohol test and he or she fails to pass that test.

(c) Only apprentices, as defined in Section 3077, who are in training under apprenticeship standards that have been approved by the Chief of the Division of Apprenticeship Standards and who are parties to written apprentice agreements under Chapter 4 (commencing with Section 3070) of Division 3 are eligible to be employed at the apprentice wage rate on public works. The employment and training of each apprentice shall be in accordance with either of the following:

(1) The apprenticeship standards and apprentice agreements under which he or she is training.

(2) The rules and regulations of the California Apprenticeship Council.

(d) If the contractor to whom the contract is awarded by the state or any political subdivision, in performing any of the work under the contract, employs workers in any apprenticeable craft or trade, the contractor shall employ apprentices in at least the ratio set forth in this section and may apply to any apprenticeship program in the craft or trade that can provide apprentices to the site of the public work for a certificate approving the contractor under the apprenticeship standards for the employment and training of apprentices in the area or industry affected. However, the decision of the apprenticeship program to approve or deny a certificate shall be subject to review by the Administrator of Apprenticeship. The apprenticeship program or programs, upon approving the contractor, shall arrange for the dispatch of apprentices to the contractor. A contractor covered by an apprenticeship program's standards shall not be required to submit any additional application in order to include additional public works contracts under that program. "Apprenticeable craft or trade," as used in this section, means a craft or trade determined as an apprenticeable occupation in accordance with rules and regulations prescribed by the California Apprenticeship Council. As used in this section, "contractor" includes any subcontractor under a contractor who performs any public works not excluded by subdivision (o).

(e) Before commencing work on a contract for public works, every contractor shall submit contract award information to an applicable apprenticeship program that can supply apprentices to the site of the public work. The information submitted shall include an estimate of journeyman hours to be performed under the contract, the number of apprentices proposed to be employed, and the approximate dates the apprentices would be employed. A copy of this information shall also be submitted to the awarding body, if requested by the awarding body. Within 60 days after concluding work on the contract, each contractor and subcontractor shall submit to the awarding body, if requested, and to the apprenticeship program a verified statement of the journeyman and apprentice hours performed on the contract. The information under this subdivision shall be public. The apprenticeship programs shall retain this information for 12 months.

(f) The apprenticeship program supplying apprentices to the area of the site of the public work shall ensure equal employment and affirmative action in apprenticeship for women and minorities.

(g) The ratio of work performed by apprentices to journeymen employed in a particular craft or trade on the public work may be no higher than the ratio stipulated in the apprenticeship standards under which the apprenticeship program operates if the contractor agrees to be bound by those standards. However, except as otherwise provided in this section, in no case shall the ratio be less than one hour of apprentice work for every five hours of journeyman work.

(h) This ratio of apprentice work to journeyman work shall apply during any day or portion of a day when any journeyman is employed at the jobsite and shall be computed on the basis of the hours worked during the day by journeymen so employed. Any work performed by a journeyman in excess of eight hours per day or 40 hours per week shall not be used to calculate the ratio. The contractor shall employ apprentices for the number of hours computed as above before the end of the contract or, in the case of a subcontractor, before the end of the subcontract. However, the contractor shall endeavor, to the greatest extent possible, to employ apprentices during the same time period that the journeymen in the same craft or trade are employed at the jobsite. When an hourly apprenticeship ratio is not feasible for a particular craft or trade, the Administrator of Apprenticeship, upon application of an apprenticeship program, may order a minimum ratio of not less than one apprentice for each five journeymen in a craft or trade classification.

(i) A contractor covered by this section who has agreed to be covered by an apprenticeship program's standards upon the issuance of the approval certificate, or who has been previously approved for an apprenticeship program in the craft or trade, shall employ the number of apprentices or the ratio of apprentices to journeymen stipulated in the applicable apprenticeship standards, but in no event less than the 1-to-5 ratio required by subdivision (g).

(j) Upon proper showing by a contractor that he or she employs apprentices in a particular craft or trade in the state on all of his or her contracts on an annual average of not less than one hour of apprentice work for every five hours of labor performed by journeymen, the Administrator of Apprenticeship may grant a certificate exempting the contractor from the 1-to-5 hourly ratio, as set forth in this section for that craft or trade.

(k) An apprenticeship program has the discretion to grant to a participating contractor or contractor association a certificate, which shall be subject to the approval of the Administrator of Apprenticeship, exempting the contractor from the 1-to-5 ratio set forth in this section when it finds that any one of the following conditions is met:

(1) Unemployment for the previous three-month period in the area exceeds an average of 15 percent.

(2) The number of apprentices in training in the area exceeds a ratio of 1 to 5.

(3) There is a showing that the apprenticeable craft or trade is replacing at least one-thirtieth of its journeymen annually through apprenticeship training, either on a statewide basis or on a local basis.

(4) Assignment of an apprentice to any work performed under a public works contract would create a condition that would jeopardize his or her life or the life, safety, or property of fellow employees or the public at large, or the specific task to which the apprentice is to be assigned is of a nature that training cannot be provided by a journeyman.

(l) If an exemption is granted pursuant to subdivision (k) to an organization that represents contractors in a specific trade from the 1-to-5 ratio on a local or statewide basis, the member contractors shall not be required to submit individual applications for approval to local joint apprenticeship committees, if they are already covered by the local apprenticeship standards.

(m) (1) A contractor to whom a contract is awarded, who, in performing any of the work under the contract, employs journeymen or apprentices in any apprenticeable craft or trade shall contribute to the California Apprenticeship Council the same amount that the director determines is the prevailing amount of apprenticeship training contributions in the area of the public works site. A contractor may take as a credit for payments to the council any amounts paid by the contractor to an approved apprenticeship program that can supply apprentices to the site of the public works project. The contractor may add the amount of the contributions in computing his or her bid for the contract.

(2) (A) At the conclusion of the 2002–03 fiscal year and each fiscal year thereafter, the California Apprenticeship Council shall distribute training contributions received by the council under this subdivision, less the expenses of the Department of Industrial Relations for administering this subdivision, by making grants to approved apprenticeship programs for the purpose of training apprentices. The grant funds shall be distributed as follows:

(i) If there is an approved multiemployer apprenticeship program serving the same craft or trade and geographic area for which the training contributions were made to the council, a grant to that program shall be made.

(ii) If there are two or more approved multiemployer apprenticeship programs serving the same craft or trade and county for which the training contributions were made to the council, the grant shall be divided among those programs based on the number of apprentices from that county registered in each program.

(iii) All training contributions not distributed under clauses (i) and (ii) shall be used to defray the future expenses of the Department of Industrial Relations for the administration and enforcement of apprenticeship standards and requirements under this code.

(B) An apprenticeship program shall only be eligible to receive grant funds pursuant to this subdivision if the apprenticeship program agrees, prior to the receipt of any grant funds, to keep adequate records that document the expenditure of grant funds and to make all records available to the Department of Industrial Relations so that the Department of Industrial Relations is able to verify that grant funds were used solely for training apprentices. For purposes of this subparagraph, adequate records include, but are not limited to, invoices, receipts, and canceled checks that account for the expenditure of grant funds. This subparagraph shall not be deemed to require an apprenticeship program to provide the Department of Industrial Relations with more documentation than is necessary to verify the appropriate expenditure of grant funds made pursuant to this subdivision.

(C) The Department of Industrial Relations shall verify that grants made pursuant to this subdivision are used solely to fund training apprentices. If an apprenticeship program is unable to demonstrate how grant funds are expended or if an apprenticeship program is found to be using grant funds for purposes other than training apprentices, then the apprenticeship program shall not be eligible to receive any future grant pursuant to this subdivision and the Department of Industrial Relations may initiate the process to rescind the registration of the apprenticeship program.

(3) All training contributions received pursuant to this subdivision shall be deposited in the Apprenticeship Training Contribution Fund, which is hereby created in the State Treasury. Upon appropriation by the Legislature, all moneys in the Apprenticeship Training Contribution Fund shall be used for the purpose of carrying out this subdivision and to pay the expenses of the Department of Industrial Relations.

(n) The body awarding the contract shall cause to be inserted in the contract stipulations to effectuate this section. The stipulations shall fix the responsibility of compliance with this section for all apprenticeable occupations with the prime contractor.

(o) This section does not apply to contracts of general contractors or to contracts of specialty contractors not bidding for work through a general or prime contractor when the contracts of general contractors or those specialty contractors involve less than thirty thousand dollars (\$30,000).

(p) An awarding body that implements an approved labor compliance program in accordance with subdivision (b) of Section 1771.5 may, with the approval of the director, assist in the enforcement of this section under the terms and conditions prescribed by the director.

## EXHIBIT 3

**AGREEMENT BETWEEN COUNTY OF MONO AND**  
Click here to enter text. **FOR THE CONSTRUCTION OF THE**  
**MONO COUNTY CIVIC CENTER TOP LIFT ASPHALT PAVING**  
**PROJECT**

### BOND REQUIREMENTS

Contractor shall furnish and maintain during the entire term of this Agreement or, if work or services do not begin as of the effective date of this Agreement, commencing at such other time as may be authorized in writing by the Director of the Department of Public Works or his designee after consultation with the County Risk Manager, the following bonds: 1) a labor and materials payment bond in an amount equal to one hundred percent (100%) of the contract price; 2) a faithful performance bond in an amount equal to one hundred percent (100%) of the contract price; and, 3) upon project completion and acceptance by the County, a one-year warranty bond in an amount equal to ten percent (10%) of the contract price. The bonds shall comply with the requirements of California Civil Code Section 9554 and must be issued by an "Admitted Surety Insurer." For purposes of this Agreement, an Admitted Surety Insurer means a corporate insurer or inter-insurance exchange to which the California State Insurance Commissioner has issued a certificate of authority to transact surety insurance in California, as defined in Section 105 of the California Insurance Code. Bonds shall be in a form acceptable to the Mono County Counsel. The Attorney-in-Fact (resident agent) who executes the bonds on behalf of the surety company must attach a copy of his Power of Attorney as evidence of his authority. A notary shall acknowledge this Power of Attorney as of the date of the execution of the surety bond that it covers. If any surety becomes unacceptable to the County or fails to furnish reports as to its financial condition as requested by County, Contractor shall promptly furnish such additional security as may be required from time to time to protect the interests of County and of persons supplying labor or materials in the prosecution of the work contemplated by this Agreement. Payment and Performance Bonds are released by County within 35 days from the date of filing of the Notice of Completion. Sample bond forms are included on the following pages.



This page intentionally left blank

SAMPLE

**SAMPLE PERFORMANCE BOND**

**WHEREAS**, the County of Mono, acting by and through its Department of Public Works, has awarded to Contractor \_\_\_\_\_ [NAME], hereafter designated as the “Contractor”, a contract for the work described as follows:

MONO COUNTY CIVIC CENTER TOP LIFT ASPHALT PAVING PROJECT as described in the Project Manual.

**AND WHEREAS**, the Contractor is required to furnish a bond in connection with said contract, guaranteeing the faithful performance thereof:

**NOW, THEREFORE**, we the undersigned Contractor and Surety are held firmly bound to the County of Mono in the sum of \_\_\_\_\_ dollars (\$ \_\_\_\_\_), to be paid to said County or its certain attorney, its successors and assigns: for which payment, well and truly to be made, we bind ourselves, our heirs, executors and administrators, successors or assigns, jointly and severally, firmly by these presents.

**THE CONDITION OF THIS OBLIGATION IS SUCH**, that if the above bound Contractor, its heirs, executors, administrators, successors or assigns, shall in all things stand to and abide by, and well and truly keep and perform the covenants, conditions and agreements in the foregoing contract and any alteration thereof made as therein provided, on his or their part to be kept and performed at the time and in the manner therein specified, and in all respects according to their intent and meaning, and shall indemnify and save harmless the County of Mono, its officers and agents, as therein stipulated, then this obligation shall become and be null and void; otherwise it shall be and remain in full force and virtue.

As a part of the obligation secured hereby and in addition to the face amount specified therefor, there shall be included costs and reasonable expenses and fees, including reasonable attorney's fees, incurred by County in successfully enforcing such obligation, all to be taxed as costs and included in any judgment rendered.

The surety hereby stipulates and agrees that no change, extension of time, alteration or addition to the terms of the agreement or to the work to be performed thereunder or the specifications accompanying the same shall in anyway affect its obligations on this bond, and it does hereby waive notice of any such change, extension of time, alteration or addition to the terms of the agreement or to the work or to the specifications.

IN WITNESS WHEREOF, We have hereunto set our hands and seals on this \_\_\_\_\_ day of \_\_\_\_\_, 20\_\_\_\_.

Correspondence or claims relating to this bond should be sent to the surety at the following address:

\_\_\_\_\_  
\_\_\_\_\_

\_\_\_\_\_  
\_\_\_\_\_

Contractor

\_\_\_\_\_  
Name of Surety (SEAL)

By: Attorney-in-Fact

NOTE: Signatures of those executing for the surety must be properly acknowledged.

APPROVED AS TO FORM:

\_\_\_\_\_  
Mono County Counsel

This page intentionally left blank

SAMPLE

**SAMPLE PAYMENT BOND**

**WHEREAS**, The County of Mono, acting by and through its Department of Public Works, hereafter referred to as "Obligee", has awarded to Contractor \_\_\_\_\_, hereafter designated as the "Principal", a contract for the work described as follows:

MONO COUNTY CIVIC CENTER TOP LIFT ASPHALT PAVING PROJECT as described in the Project Manual.

**AND WHEREAS**, said Principal is required to furnish a bond in connection with said contract, to secure the payment of claims of laborers, mechanics, materialmen and other persons as provided by law.

**NOW, THEREFORE**, we the undersigned Principal and Surety are bound unto the Obligee in the sum of \_\_\_\_\_ dollars (\$ \_\_\_\_\_), for which payment, we bind ourselves, jointly and severally.

**THE CONDITION OF THIS OBLIGATION IS SUCH,**

That if said Principal or its subcontractors shall fail to pay any of the persons named in Civil Code Section 9100, or amounts due under the Unemployment Insurance Code with respect to work or labor performed by such claimant, or any amounts required to be deducted, withheld, and paid over to the Employment Development Department from the wages of employees of the Principal and his subcontractors under Section 13020 of the Unemployment Insurance Code, with respect to such work and labor, that the surety herein will pay for the same in an amount not exceeding the sum specified in this bond, otherwise the above obligation shall be void. In case suit is brought upon this bond, the surety will pay a reasonable attorney's fee to be fixed by the court. This bond shall inure to the benefit of any of the persons named in Civil Code Section 9100 as to give a right of action to such persons or their assigns in any suit brought upon this bond.

The surety hereby stipulates and agrees that no change, extension of time, alteration or addition to the terms of the agreement or to the work to be performed thereunder or the specifications accompanying the same shall in anywise affect its obligations on this bond, and it does hereby waive notice of any such change, extension of time, alteration or addition to the terms of the agreement or to the work or to the specifications.

Dated: \_\_\_\_\_, 20 \_\_\_\_\_

Correspondence or claims relating to this bond should be sent to the surety at the following address:

\_\_\_\_\_

\_\_\_\_\_

Principal

\_\_\_\_\_

\_\_\_\_\_

Surety (SEAL)

\_\_\_\_\_

\_\_\_\_\_

By: Attorney-in-Fact

NOTE: Signatures of those executing for the surety must be properly acknowledged.

APPROVED AS TO FORM:

\_\_\_\_\_  
Mono County Counsel

This page intentionally left blank

SAMPLE

**SAMPLE WARRANTY BOND**

**KNOW ALL BY THESE PRESENTS** that we, \_\_\_\_\_, the Contractor in the contract hereto annexed, as Principal, and, \_\_\_\_\_ as Surety, are held and firmly bound unto the County of Mono in the sum of \_\_\_\_\_ (\$ \_\_\_\_\_) lawful money of the United States, for which payment, well and truly to be made, we bind ourselves, jointly and severally, firmly by these presents.

Signed, Sealed, and Dated

The condition of the above obligation is that if said Principal, its successors and assigns, as Contractor in the contract for the work described herein, or its subcontractor, fails to maintain and remedy in a good workmanlike manner the work of the MONO COUNTY CIVIC CENTER TOP LIFT PAVING PROJECT such that it is free from defects in materials and workmanship for a period of one year commencing on \_\_\_\_\_ [DATE] (the "Maintenance Period") and shall indemnify and save harmless the County of Mono, its officers and agents, as stipulated in the contract, said Surety will pay for the same in an amount not to exceed the sum hereinabove set forth, and also in case suit is brought upon this bond, a reasonable attorney's fee to be fixed by the court.

**PROVIDED, HOWEVER**, that any suit under this bond shall be commenced no later than one (1) year from the expiration date of the Maintenance Period; provided, however, that if this limitation is prohibited by any law controlling the construction hereof, such limitation shall be deemed to be amended so as to be equal to the minimum period of limitation permitted by such law, and said period of limitation shall be deemed to have accrued and shall commence to run on the expiration date of the Maintenance Period.

Dated: \_\_\_\_\_, 20 \_\_\_\_\_

Correspondence or claims relating to this bond should be sent to the surety at the following address:

\_\_\_\_\_  
\_\_\_\_\_  
Principal

\_\_\_\_\_  
\_\_\_\_\_  
Surety (SEAL)

\_\_\_\_\_  
By: Attorney-in-Fact

NOTE: Signatures of those executing for the surety must be properly acknowledged.

APPROVED AS TO FORM:

\_\_\_\_\_  
Mono County Counsel

This page intentionally left blank

SAMPLE

## EXHIBIT 4

### AGREEMENT BETWEEN COUNTY OF MONO AND [Click here to enter text.](#) FOR THE CONSTRUCTION OF THE MONO COUNTY CIVIC CENTER TOP LIFT ASPHALT PAVING PROJECT

#### INVOICING, PAYMENT AND RETENTION

3.E. (1). Invoicing and payment. Contractor shall submit to County, not more than once per month, a payment request in the form of an itemized statement of all services and work described in the Scope of Work (Attachment A) and Contract Documents, which were done at County's request. The statement to be submitted will cover the period from the first day of the preceding month through and including the last day of the preceding month. Alternatively, Contractor may submit a single request for payment at the conclusion of the work. All statements submitted in request for payment should identify the date on which the services and work were performed and describe the nature of the services and work which were performed on each day. Invoices shall be informative and concise regarding work performed during that billing period.

If this box is checked, then invoicing shall be made in the format and according to the schedule and payment terms set forth in the Application and Certificate for Payment set forth on the following two (2) pages.

The progress of work shall initially be determined by Contractor, but must then be approved in writing by County. Additionally, the making of one or more (1+) progress payments shall not be construed as approval of the work performed by Contractor. Should Contractor submit an improper payment request, County shall, as soon as practicable, return the request to Contractor accompanied by a document setting forth the reasons why the payment request is not proper. Should County determine the services or work have not been completed or performed as called for in the Scope of Work (Attachment A) and/or the Contract Documents and/or should Contractor submit an improper payment request, then County shall withhold payment of any disputed amount, plus those amounts authorized by Public Contract Code section 7107, until the services and work are satisfactorily completed or performed and/or the payment request is corrected and resubmitted.

Final payment (excluding retention) for work completed by the Completion Date specified in the Notice of Completion, shall be made within 35 days from the date that County records the Notice of Completion.

3.E.(2). Retention. In accordance with Public Contract Code sections 9203 and 20104.50, County shall retain five percent (5%) of each progress payment until the Project is completed unless, at any time after fifty percent (50%) of the work has been completed, the Board of Supervisors finds that satisfactory progress is being made, in which case County may make any of the remaining progress payments in full for actual work completed. In accordance with Public Contract Code section 22300, Contractor may substitute securities for any moneys withheld by County to ensure performance under this Agreement or request County to make payments of the retention earnings directly to an escrow agent at Contractor's expense.

Retention for work completed by the Completion Date will be released within 60 days of the date County records the Notice of Completion.



This page intentionally left blank

SAMPLE

# **SECTION III**

## **TECHNICAL SPECIFICATIONS & QUALITY ASSURANCE PROGRAM**

**Mono County Civic Center  
Top Lift Asphalt Paving Project**

This page intentionally left blank

**TECHNICAL SPECIFICATIONS**

MONO COUNTY CIVIC CENTER

TOP LIFT ASPHALT PAVING

Project No. MCCC PAVING

<b>Table of Contents</b>	<b>Page Number</b>
<b>1. DESCRIPTION OF WORK</b>	<b>3</b>
<b>5. CONTROL OF WORK AND MATERIALS</b>	<b>3</b>
<b>8. MOBILIZATION</b>	<b>5</b>
<b>12. TEMPORARY TRAFFIC CONTROL</b>	<b>5</b>
<b>13. WATER POLLUTION CONTROL</b>	<b>7</b>
<b>15. PROTECTION OF EXISTING FACILITIES</b>	<b>8</b>
<b>17. CLEARING AND GRUBBING</b>	<b>9</b>
<b>18. DUST CONTROL</b>	<b>10</b>
<b>19. EARTHWORK</b>	<b>10</b>
<b>19.1 GENERAL</b>	<b>10</b>
<b>19.2 ROADWAY EXCAVATION</b>	<b>11</b>
<b>19.9 SHOULDER BACKING</b>	<b>12</b>
<b>26. AGGREGATE BASE</b>	<b>13</b>
<b>39. ASPHALT CONCRETE</b>	<b>15</b>

This page intentionally left blank

## **1. Description of Work**

The **MONO COUNTY CIVIC CENTER TOP LIFT ASPHALT PAVING PROJECT** (hereinafter referred to as the project) is for the purpose of placing asphalt serving the new Mono County Civic Center in Mammoth Lakes including: a top lift of asphalt on portions of Tavern Road and Thompsons Way; a parking area on the northwest of the building; and, potentially, a sidewalk along Tavern Road.

There may be other items of work not mentioned above that are required by the 2015 State of California, Department of Transportation, Standard Specifications, (hereinafter referred to as CT Specifications), or these Technical Specifications. Project work shall conform to the plans, project specifications, including these Technical Specifications, and the CT Specifications.

## **5. Control of Work and Materials**

General:

All work performed in connection with CONTROL OF WORK AND MATERIALS shall conform to the provisions in CT Specifications Section 13 "WATER POLLUTION CONTROL". Section 5, "CONTROL OF WORK," and Section 6, "CONTROL OF MATERIALS" and these Technical Specifications.

Submittals:

The Contractor shall provide an 'electronic file' of submittals for each of the following items to the Engineer:

1. Construction Schedule
2. Temporary Traffic Control Plan
3. Bituminous Seals (Slurry Seal Mix Design, Asphalt-Rubber Chip Seal Mix Design, Flush Coat Mix Design, Hot Mix Asphalt Mix Design)
4. Paint Certificates of Compliance
5. Sign Certificates of Compliance
6. Concrete Mix Design
7. Class 2 Aggregate Base Manufacturer's Specifications
8. Shoulder Backing Manufacturer's Specifications

The Engineer reserves the right to require additional submittals from the Contractor that are not specifically identified above. If so requested, the Contractor shall provide the Engineer with an 'electronic file' of any additional submittals.

Construction:

Work shall progress only after engineer's approval of the Construction Schedule Submittal. The construction schedule shall include consideration and coordination with Roebbelen Construction.

The Contractor shall coordinate with Mono County and Roebbelen Construction regarding establishment and operation of storage and staging areas.

24 Hour Contact Number - The Contractor shall assign a project superintendent and an assistant who have the complete authority to make decisions on behalf of the Contractor. The project

superintendent or the assistant shall be at the project site at all times during the construction and shall be available and on call 24 hours a day, 7 days per week for the duration of the project. The Contractor shall provide the Engineer and the Mono County Sheriff's Department primary and secondary 24-hour mobile phone numbers for the project superintendent and the assistant. These numbers shall not automatically direct calls to a recorder or other message taking service.

Advance Public Notification – At least 7 days and no more than 14 days prior to beginning any work on the project, the Contractor shall sign or post written notice in each community and notify other applicable parties listed below. Notice shall be given for general construction activity in an area as well as specific activities that will, in any way, inconvenience residents/property owners/tenants or affect their operations or access to their property. Such notices shall include the expected date for start of construction, a general description of the construction activity to take place, expected duration, streets, limits of activities, work hours, and the name, address, and contact number of the Contractor's superintendent and Mono County Public Works.

The Contractor shall provide Advance Notice and coordinate the work with the following parties.

Mono County Sheriff's Department	760-932-7549
Mono County Fire / Rescue Department	760-387-2955
USFS – (Inyo National Forest – Mammoth Ranger Station)	760-924-5500
Caltrans Encroachment Permit Office	760-872-0674
SCE	760-924-4810

Payment:  
There is no separate payment for Control of Work.

**8. Mobilization**

General:  
Mobilization shall consist of preparatory work and operations, including, but not limited to, those necessary for the movement of personnel, equipment, supplies and incidentals to and from the project site.

Submittals:  
Construction Schedule

Payment:  
The contract LUMP SUM price paid for MOBILIZATION shall constitute full compensation for furnishing all labor and materials, including tools, equipment and incidentals, and for performing the work involved in placing, removing, storing, maintaining, moving to new locations, replacing, and disposing of equipment and materials, creating as-built drawings, and for performing all work required for which separate payment is not otherwise provided as specified in the CT Specifications and these Technical Specifications, and as directed by the Engineer. No adjustment will be made to the lump sum price for mobilization due to the requirement of a winter suspension, two mobilizations,

or changes to other items of work or additions to the Contract. The contract LUMP SUM payments for MOBILIZATION will only be paid as work begins in each project area designated on the Bid Sheets.

## **12. Temporary Traffic Control**

### General:

All work performed in connection with TEMPORARY TRAFFIC CONTROL shall conform to the provisions in CT Specifications Section 12 TEMPORARY TRAFFIC CONTROL. Sections 7- 1.08, "Public Convenience," 7-1.09, "Public Safety," and Section 12, "Construction Area Traffic Control Devices," and these Technical Specifications. Nothing in these Technical Specifications shall be construed as relieving the Contractor from the responsibilities specified in Section 7-1.09.

At the pre-construction meeting, the traffic control requirements for the project shall be reviewed with the Contractor including all of the Contractor's foremen or supervisors.

### Submittals:

Temporary Traffic Control Plan. The plan shall meet CA MUTCD requirements and include Caltrans Standard Plan Details, Temporary Facilities, as necessary to provide for traffic access and safety during construction.

The Contractor shall submit a traffic control plan prepared by a Civil Engineer. The traffic control plan shall meet the requirements of the Caltrans encroachment permit. If acceptable to Caltrans, applicable Caltrans Standard Plans (T-sheets) may be used in lieu of a traffic control plan prepared by a Civil Engineer.

### Construction:

The Contractor shall post "No Parking" signs, as necessary, not less than 72 hours in advance of scheduled work that will restrict parking. No Parking signs shall include specific dates, including day of the week and hours parking and access will be restricted. If the work is not performed during the timeframe indicated on the "No Parking" signs, the work shall be rescheduled with at least three (3) working days advance notice.

The Contractor shall leave the street open to traffic.

A minimum of one paved traffic lane, not less than ten (10) feet wide, shall be open for use by public traffic in each direction of travel except for single direction traffic control with flaggers as approved by the Engineer. Traffic may not be routed over unpaved roadways unless authorized by the Engineer.

Except for temporary interruptions approved by the Engineer, Contractor shall maintain property owner access to their property over both walkways and driveways at all times.

The Contractor shall maintain a safe workplace at all times, including, but not limited to, providing flaggers, safety equipment, barricades, safe pedestrian passage along sidewalks, and maintenance of handicap access throughout the project site where applicable.

The Contractor shall fulfill the requirements of this section 24 hours per day, seven days per week,



including holidays, from the time the Notice to Proceed is issued until the project is accepted as complete.

Whenever vehicles or equipment are parked on the shoulder within 6 feet of a traffic lane, the shoulder area shall be closed with fluorescent traffic cones or portable delineators placed on a taper in advance of the parked vehicles or equipment and along the edge of the pavement at 25-foot intervals to a point not less than 25 feet past the last vehicle or piece of equipment. A minimum of 9 cones or portable delineators shall be used for the taper. A C23 (Road Work Ahead) or C24 (Shoulder Work Ahead) sign shall be mounted on a portable sign stand with flags. The sign shall be placed as approved by the Engineer.

When entering or leaving roadways carrying public traffic, the Contractor's equipment, whether empty or loaded, shall in all cases yield to public traffic.

All excess and unsuitable material resulting from the Contractor's operation shall be removed from the project site before the end of each workday.

**Payment:**

The contract LUMP SUM price paid for "TRAFFIC CONTROL" shall include full compensation for furnishing all labor, materials (including signs, arrow boards, barricades and cones), tools, equipment and incidentals, preparing the required traffic control plans, and providing construction and detour signs, flaggers, police support and the installation and subsequent removal of signing, and for doing all the work involved in placing, removing, storing, maintaining, moving to new locations, replacing and disposing of the components of the traffic control system as shown on the plans, as specified in the CT Specifications and these Technical Specifications, and as directed by the Engineer. The LUMP SUM price paid for "TRAFFIC CONTROL" applies only to the specific area of construction identified on the Bid Sheets.

### **13. Water Pollution Control**

**General:**

All work performed in connection with WATER POLLUTION CONTROL shall conform to the provisions in CT Specifications Section 13 WATER POLLUTION CONTROL, the plans and these Technical Specifications.

This project does not include any earth disturbing activities. Dust and sediment may be created by this project while cleaning the pavement surfaces. The intent of the WATER POLLUTION CONTROL is to eliminate the potential for this dust or sediment to exit the project site in any form of runoff and to conform to any federal, state and/or local requirements.

**Submittals:**

Fiber Roll must be certified seed proof.

**Materials: Fiber**

Rolls

Other BMP's as determined in the field

Construction:

Work shall be scheduled for time when there is no stormwater runoff entering or exiting the site, except as authorized by the engineer.

No construction debris shall be allowed to exit the site.

Contractor shall have pavement sweeping and vacuuming equipment to collect sediment, dust and debris to eliminate the potential for construction debris from existing the site.

Contractor may be required to have Fiber rolls available in the instance that a rainstorm is predicted while there is sediment on the paved surfaces. If sediment is continuously removed from paved surface, fiber rolls may not be required.

Work shall include furnishing all labor, materials (including fiber rolls, silt fences, geotextiles, etc.), tools, equipment and incidentals, and providing the required BMPs and subsequent removal of BMPs, and for performing all the work involved in placing, removing, storing, maintaining, moving to new locations, replacing and disposing of the components of the erosion control system as shown on the plans, as specified in the CT Specifications and these Technical Specifications, and as directed by the Engineer.

No vegetation shall be removed under this project.

Project Winterization:

This project is not expected to require winterization. If winterization is required all costs associated with it will be the responsibility of the Contractor. Winterization would include cleaning all surfaces of sediment, debris and dust. If there is a winter shutdown, no work will be permitted in project areas that have not been started.

Payment:

The contract LUMP SUM price paid for "WATER POLLUTION CONTROL" shall include full compensation for furnishing all labor, materials (including fiber rolls, silt fences, geotextiles, etc.), tools, equipment and incidentals, and providing the required BMPs and subsequent removal of BMPs, and for doing all the work involved in placing, removing, storing, maintaining, moving to new locations, replacing and disposing of the components of the WATER POLLUTION CONTROL as shown on the plans, as specified in the CT Specifications and these Technical Specifications, and as directed by the Engineer.

## **15. Protection of Existing Facilities**

General:

Existing facilities requiring adjustment include removal and connection to existing storm drainage. All work performed in connection with PROTECTION OF EXISTING FACILITIES shall conform to the provisions in Section 15, "Existing Highway Facilities," and Section 4-1.03D "Changes" of the CT Specifications and these Technical Specifications.

Construction:

**Existing underground utility lines are not shown on the plans.** This project includes only surface work. The Contractor shall be responsible for locating and field verifying the location of all existing

utilities and utility features prior to the start of construction activities and protecting all facilities during construction. (Note: There is a fiber optic line in the vicinity of this project.) Engineer shall be notified of utility conflicts. Contractor shall allow 14 days after notification of utility conflicts prior to construction of affected work. Damage caused by the Contractor to existing facilities shall be repaired within 24 hours at the sole expense of the Contractor.

**Existing overhead utility lines are not shown on the plans.** The contractor shall take all precautionary measures necessary to protect overhead utility lines and protect workers and pedestrians during construction operations.

The Contractor shall notify and coordinate the work of identifying and marking utility facilities with the respective utility companies. The Contractor is required to call Underground Service Alert (USA) at 811 forty-eight (48) hours in advance of any excavation activity. The Contractor shall submit to the Engineer copies of all USA confirmation numbers including associated documentation.

Existing survey monuments shall be preserved, referenced or replaced pursuant to the requirements of State of California Streets and Highways Code Sections 732.5, 1492.5, and 1810.5 and Business and Professions Code Section 8771 and the following:

The Contractor shall not disturb permanent survey monuments or benchmarks except as shown on the plans and as approved by the Engineer. The Contractor shall bear the expense of replacing any monuments or benchmarks that may be disturbed without permission. Replacement shall be done only by a registered Land Surveyor in the presence of the Engineer.

Should the Contractor during the course of construction encounter a survey monument or benchmark not shown on the plans, he shall promptly notify the Engineer so that the monument or benchmarks may be referenced accordingly.

**Payment:**

Full compensation for protection of existing facilities and for preservation of existing survey monuments, except those noted on the plans as requiring replacement and paid for separately, shall be considered as included in the contract prices paid for the various items of work, and no additional compensation will be allowed therefor.

## **17. Clearing and Grubbing**

**General:**

Clearing and grubbing consists of removing objectionable material from the following construction areas:

1. Highways
2. Bridges and other structures
3. Roads, road approaches, streets, and ramps
4. Material sites
5. Ditches and channels
7. Other described areas

Clear and grub before performing earthwork in a project area.

Do not injure standing trees, plants, and improvements shown to be protected.

**Clearing:**

Clear all construction areas above original ground of (1) all vegetation such as trees, logs, upturned stumps, roots of downed trees, brush, grass, and weeds and (2) other objectionable material including concrete, masonry, and debris. Cut tree branches that extend over the roadway and hang within 20 feet of finished grade.

**Grubbing:**

Grub all construction areas to a depth necessary to remove all trees, existing stumps, roots, buried logs, and other vegetative or objectionable material.

**Disposal of Materials:**

Dispose of materials resulting from clearing and grubbing activities legally at a landfill or the material may be disposed of on-site with approval from the Engineer. Dispose of hazardous material according to Federal, state, and local regulations.

**Payment:**

Full compensation for CLEARING AND GRUBBING shall be considered as included in the prices paid for the various items of work involved, and no separate payment will be made therefor.

**18. Dust Control**

**General:**

All work performed in connection with DUST CONTROL shall conform to the provisions in CT Specifications Section 18 DUST PALLIATIVES.

**Construction:**

The Contractor shall perform necessary work to control dust at all times as required by regulation. In particular, contractor shall make every effort to collect debris and dust created by cleaning the roadway surface in preparation for chip sealing and slurry sealing activities.

Sweep up or vacuum any residue before it can be blown by traffic or wind, migrate across lanes or shoulders, migrate to adjacent soils or enter a drainage facility.

Debris collected shall be disposed of legally, such as at a landfill facility.

**Payment:**

Full compensation for DUST CONTROL including but not limited to that resulting from construction, public traffic, or wind shall be considered as included in the prices paid for the various items of work involved, and no separate payment will be made therefor.

**19. Earthwork**

## 19.1 General

All work performed in connection with EARTHWORK shall conform to the provisions in CT Specifications Section 19 EARTHWORK.

Performing earthwork activities includes removal of unsuitable material or a buried man-made object if the removal is described. The work also consists of salvaging, removing, and disposing of fences, structures, pavements, culverts, utilities, curbs, sidewalks, signs, snowpoles, and other obstructions within the project earthwork area.

Excavated material may be used as road shoulder fill if approved by the Engineer.

### Unsuitable Material:

Excavate and dispose of unsuitable material encountered below the natural ground surface in embankment areas or below the grading plane in excavation areas as ordered.

Notify the Engineer before removing the unsuitable material if:

1. Removal is not otherwise described
2. You request payment for removal as change order work

Backfill the space resulting from excavating unsuitable material with material suitable for the planned use.

### Buried Man-Made Objects:

Remove and dispose of a buried man-made object encountered in an excavation as part of the excavation work.

Notify the Engineer before removing the buried man-made object if:

1. Removal of the object is not otherwise described
2. Object could not have been determined by visual inspection
3. You request payment for removal of the object as change order work

## 19-2. Roadway Excavation

Roadway excavation consists of all excavation involved in the grading and construction of the roadway except structure excavation and any excavation paid for as a separate bid item.

Roadway excavation includes:

1. Excavating and stockpiling the selected material
2. Removing the stockpiled material and placing it in its final position
3. Removing surcharge material
4. Performing the removal of a slide or slipout which is paid for as the type of roadway excavation involved

### Construction:

Excavate to the described or authorized grade. If you over-excavate, backfill with an authorized material and compact it.

Remove pavement within the limits of roadway excavation. Pavement removal must comply with Section 39 of these specifications.

Payment:

The payment quantity for ROADWAY EXCAVATION (REPAIR AREAS) is the volume of roadway excavation material in CUBIC YARDS (CY) and includes full compensation for furnishing all labor, materials, tools, equipment, hauling, storing, placing, disposal, compaction, and other incidentals, and for doing all the work involved complete in place, as shown on the plans, as specified in the CT Specifications and these Technical Specifications, and as directed by the Engineer.

**19-9 Shoulder Backing**

Materials:

Shoulder backing must be clean and consist of one or any combination of the following materials:

1. Broken stone
2. Crushed gravel
3. Natural rough surfaced gravel
4. Sand
5. RAP
6. Concrete
7. LCB
8. CTB

Shoulder backing must be graded within the percentage passing limits shown in the following table:

Sieve size	Percentage passing
2"	100
1"	75–100
3/4"	65–100
No. 4	35–60
No. 30	10–35
No. 200	5–15

If 100 percent RAP is used, shoulder backing must be graded within the percentage passing limits shown in the following table:

Sieve size	Percentage passing
1-1/2"	100
3/4"	70–100
No. 4	30–80

Shoulder backing must comply with the sand equivalent requirements shown in the following table:

Quality characteristics	Test method	Requirement

Sand Equivalent		
Single type of material except RAP		10-35
Combination of all type of materials including RAP	California Test 217	10-35
Combination of all type of materials excluding RAP		10-30
100% RAP (min)		10

**Construction:**

Do not place shoulder backing containing RAP within 100 feet measured horizontally from a culvert, watercourse, or bridge.

Remove weeds, grass, and debris from the area to receive shoulder backing.

Scarify the basement material to receive shoulder backing at least 0.25-foot deep and water immediately before placing the shoulder backing.

Place and spread shoulder backing directly on the basement material. After placing the shoulder backing, water and compact it with a minimum of 2 passes with a steel-tired roller weighing at least 8 tons. Wherever the total thickness of shoulder backing is more than 6 inches, place the backing under sections 19-5 and 19-6 of the CT Standard Specifications. Form smooth and uniform cross sections and slopes.

**Compaction:**

Relative compaction specifications apply to material whether in an excavation or an embankment.

The moisture content of material to be compacted to at least 95 percent must be such that the specified relative compaction is attained and the embankment is in a firm and stable condition.

Do not compact material that contains excessive moisture until the material is dry enough.

**Payment:**

SHOULDER BACKING (IMPORT) is paid for by the LINEAR FOOT (LF). The payment quantity for SHOULDER BACKING is the horizontal length of shoulder backing placed parallel to the road centerline. The County does not increase the embankment quantity if subsidence or consolidation occurs after you start placing the backing material.

The contract unit price paid shall include full compensation for furnishing all labor, materials, tools, equipment, compaction, and incidentals, and for doing all the work involved, complete in place, as shown on the plans or matching existing locations, as specified in the CT Specifications and these Technical Specifications and as directed by the Engineer.

## 26. Aggregate Base

Acceptance:

The County accepts aggregate base (AB) based on aggregate gradation, sand equivalent requirements, and percent relative compaction per ASTM D6938 or CT 231. Resistance (R-value) and Durability Index are not required to be tested for during construction, but the AB must meet the minimum requirements for both per the material specification sheet provided by the manufacturer.

If the aggregate gradation test results, sand equivalent test results, or both do not comply with Contract compliance requirements, remove the AB or request a payment deduction. If your request is authorized, \$2.00/cu yd is deducted.

Aggregate must be clean and consist of any combination of the following:

1. Broken stone
2. Crushed gravel
3. Natural rough-surfaced gravel
4. Sand
5. Processed reclaimed asphalt concrete, PCC, LCB, or CTB

Use 3/4-inch maximum aggregate gradation unless otherwise specified. Do not change your selected aggregate gradation without authorization.

Class 2 Aggregate Base:

Aggregate gradation must be within the percentage passing limits for the sieve sizes shown in the following table:

Sieve size	Percent Passing	
	3/4 inch maximum	
	Operating range	Contract compliance
2"	--	--
1-1/2"	--	--
1"	100	100
3/4"	90–100	87–100
No. 4	35–60	30–65
No. 30	10–30	5–35
No. 200	2–9	0–12

The aggregate quality characteristics must comply with the requirements shown in the following table:

Aggregate Quality Characteristics

Quality characteristic	Requirement	
	Operating range	Contract compliance
Resistance (R-value, min)	--	78
Sand equivalent (min)	25	22
Durability index (min)	--	35



**Construction:**

Apply water to the AB to obtain optimum water content needed for compaction. Water content shall be  $\pm 2.0\%$  of optimum.

**Subgrade:**

Immediately before spreading AB, the subgrade must comply with the specified compaction and elevation tolerance for the material involved and be free from loose or extraneous material. You may use AB to fill areas of the subgrade that are lower than the grade established by the Engineer.

**Spreading:**

Deliver uniform mixtures of AB to the roadbed. Deposit AB in layers or windrows. Spread and shape the AB to such thickness that after watering and compacting, the completed AB is within 0.05 feet from the grade established by the engineer. When AB is spread and compacted the moisture content must be uniform and sufficient to obtain the required compaction. Avoid material segregation. AB must be free from pockets of coarse or fine material.

If the subgrade is cohesionless sand, you may dump AB in piles and spread it ahead in sufficient quantities to stabilize the subgrade, if authorized.

If the AB thickness shown is 0.50 foot or less, spread and compact the AB in at least 1 layer. If the thickness shown is more than 0.50 foot, spread and compact the AB in at least 2 approximately equal layers in thickness. The compacted thickness of any one layer must not exceed 0.50 foot.

**Compacting:**

Compact each AB layer to at least 95 percent relative compaction.

Correct areas of AB that do not comply with the described thickness or request a payment deduction if AB is paid for by volume. If your request is authorized, the Engineer calculates the deduction by multiplying:

1. Deficient thickness less allowable tolerance
2. Planned width
3. Longitudinal distance of the deficient thickness
4. \$17.00/cu yd or the item bid price adjusted for cubic yards, whichever is higher

**Payment:**

Payment shall be made at the contract unit price per volume (CUBIC YARDS, CY) for 4" AGGREGATE BASE (NEW 5-FOOT WIDE SIDEWALK). The payment quantity does not include the volume of aggregate base used to fill low areas of the subgrade. The contract unit price paid shall include full compensation for furnishing all labor, materials, tools, equipment, and incidentals, and for doing all the work involved, complete in place, as shown on the plans or matching existing locations, as specified in the CT Specifications and these Technical Specifications and as directed by the Engineer.

**39. Asphalt Concrete**

Replace Asphalt Concrete Surfacing:

Submittals:

Asphalt concrete mix design shall be submitted to Mono County Engineer for approval.

**Materials:**

HMA to be used for replacing asphalt concrete surfacing must be Type A or Type B 1/2" HMA polymer modified (preferred) or unmodified. RAP may be used in the mix design. The grade of asphalt binder shall be PG 64-28.

Tack coat must comply with section 39-2.01B(10) of the CT Standard Specifications.

**Construction:**

Where replace asphalt concrete surfacing is shown, remove the full depth of the existing asphalt concrete surfacing and replace with HMA.

Replace asphalt concrete in a lane before the lane is specified to be opened to traffic.

Before removing asphalt concrete, outline the replacement area and cut neat lines with a saw or grind to full depth of the existing asphalt concrete. Do not damage asphalt concrete and base remaining in place. The Engineer determines the exact limits of asphalt concrete surfacing to be replaced.

Before placing HMA, apply a tack coat as specified in section 39-2.01C(3)(f).

Place HMA using method compaction as specified in section 39-2.01C(2)(c).

**Payment:**

The payment quantity for 1.5-INCH HOT MIX ASPHALT is measured based on the combined mixture weight (TONS) of material actually used based on batch weights or truck scale weights with a licensed Weighmaster's Certificate. Time, date, mix number, load number, and truck identification must be provided on each load ticket.

The payment quantity for 3-INCH HOT MIX ASPHALT is measured based on the combined mixture weight (TONS) of material actually used based on batch weights or truck scale weights with a licensed Weighmaster's Certificate. Time, date, mix number, load number, and truck identification must be provided on each load ticket.

The payment quantity for 2.5-INCH HOT MIX ASPHALT is measured based on the combined mixture weight (TONS) of material actually used based on batch weights or truck scale weights with a licensed Weighmaster's Certificate. Time, date, mix number, load number, and truck identification must be provided on each load ticket.

The payment quantity for HOT MIX ASPHALT TRENCH PATCH is measured based on the combined mixture weight (TONS) of material actually used based on batch weights or truck scale weights with a licensed Weighmaster's Certificate. Time, date, mix number, load number, and truck identification must be provided on each load ticket.

This page intentionally left blank



**DEPARTMENT OF PUBLIC WORKS**

# **QUALITY ASSURANCE PROGRAM (QAP)**

---

## Table of Contents

	Page
A. Definition of Terms	2
B. Materials Acceptance Program	2
1. Field Sampling and Acceptance Program	2
2. Manufacturer's Certificate of Compliance	4
3. Source Inspection and Testing	5
4. Visual Inspection	5
C. Independent Assurance Program (IAP)	5
D. Resident Engineers Certification of Project Materials	6
E. Project QAP Records	6
Attachment No. 1: Acceptance Sampling and Testing Frequency Table	8

# QUALITY ASSURANCE PROGRAM (QAP)

## AGENCY: County of Mono

The purpose of this program is to provide assurance that the materials incorporated into the construction projects are in conformance with the contract specifications. This program should be updated every five years or more frequent if there are changes to the testing and sampling frequencies or to the test methods.

Except as revised by this QAP, work shall be done in conformance with Division of Local Assistance, Office of Procedures Development and Training Quality Assurance Program (CT-QAP) Manual for Use by Local Agencies, Revised January 20, 2011 which can be found at [http://www.dot.ca.gov/hq/LocalPrograms/public/QAP\\_Manual.pdf](http://www.dot.ca.gov/hq/LocalPrograms/public/QAP_Manual.pdf).

### A. DEFINITION OF TERMS

- Acceptance Testing (AT)— Sampling and testing, or inspection, to determine the degree of compliance with contract requirements.
- CT— California Department of Transportation (Caltrans)
- Certificate of Compliance— A signed document from the materials manufacturer committing that the delivered goods meet the contract specifications
- Independent Assurance Program (IAP)— Verification that AT is being performed correctly by qualified testers and laboratories.
- Material Acceptance Program— Sampling, Testing, inspection, and certification of project materials to determine compliance with contract specifications.
- Quality Assurance Program (QAP)— A sampling and testing program that will provide assurance that the materials and workmanship incorporated into the construction project are in conformance with the contract specifications. The main elements of a QAP are the Materials Acceptance Program and the Independent Assurance Sampling and Testing Program (IAP).
- Source Inspection— Sampling, testing, and/or inspection of manufactured or prefabricated structural materials at a location other than the job site, generally at the manufactured location.

### B. MATERIALS ACCEPTANCE PROGRAM

Material incorporated into the work shall be accepted by one or more of the following methods, as specified in this document and the contract specifications:

1. *Field Sampling and Acceptance Testing*
2. *Manufacturer's Certificate of Compliance* (with attachments if required)
3. *Source Inspection and Testing*
4. *Visual Inspection* (for minor quantities)

#### 1. Field Sampling and Acceptance Testing (AT)

AT will be performed by a materials laboratory certified to perform the required tests. The tests results will be used to ensure that all materials incorporated into the project are in compliance with the contract specifications.

Testing methods will be in accordance with the CT Methods or a national recognized standard (i.e., AASHTO, ASTM, etc.) as specified in the contract specifications.

#### General:

- Acceptance sampling and testing shall be performed by certified materials personnel.
- Acceptance testing will be performed utilizing accredited materials laboratories and properly calibrated equipment.
- Certifications and accreditations shall be specific to the tests being performed.
- A materials testing results log shall be maintained for any test method performed more than once on a project.
- The test results for materials incorporated into the work shall be in compliance with the contract specifications.
- Actions taken regarding material with failing test results will be fully documented, including details documenting remove/replace, rework/re-test, and deduction/Construction Change Order.

- Justification shall be provided for any failing material allowed to remain in place.
- At the County's digression, products may be accepted beyond the annual certification requirement, where Material Mix Designs have been used with continuous positive results and where there has been and will continue to be a consistent use of the same materials.

**Sampling and Testing Locations and Frequencies:**

- Sample and testing locations and frequencies shall be in accordance with the contract specifications.
- If not specified in the contract documents, sampling and testing locations and frequencies shall be as shown in **Attachment No. 1, Acceptance Sampling and Testing Frequency Table.**
- When sampling products such as Portland cement concrete, cement-treated base, hot mix asphalt, or similar materials; the time of such sampling shall be varied with respect to the time of the day, insofar as possible, in order to avoid a predictable sampling routine.

**Acceptance Test Methods:**

- The test methods used shall be *as specified in the contract documents.*
- For a material specified to comply with a property shown in the following table, the Agency tests under the corresponding test shown:

Test Property	Test
Relative compaction	ASTM D1557, D6938, D2950
Sand equivalent	CT 217
Resistance (R-value)	CT 301
Gradation (sieve analysis)	CT 202
Durability index	CT 229
Cleanness Value	CT 227

**Acceptance Testing Laboratory:**

The AGENCY will use a private consultant materials laboratory to perform AT on Federal-aid and other designated projects. The materials laboratory shall be under the responsible management of a California registered Engineer with experience in sampling, inspection and testing of construction materials. The Engineer shall certify the results of all tests performed by laboratory personnel under the Engineer's supervision. The materials laboratory shall contain certified test equipment capable of performing the tests conforming to the provisions of this QAP. Laboratories shall comply with part C. *Independent Assurance Program* of this document.

The materials laboratory used shall provide documentation that the laboratory complies with the following procedures:

- 1) Correlation Testing Program — The materials laboratory shall be a participant in one or more of the following testing programs:
  - a) AASHTO Materials Reference Laboratory (AMRL)
  - b) Cement and Concrete Reference Laboratory (CCRL)
  - c) Caltrans' Reference Samples Program (RSP)

The AT laboratory qualification shall occur annually.

A copy of the current laboratory qualification shall be kept in the project records.

- 2) Certification of Personnel — The materials laboratory shall employ personnel who are certified by one or more of the following:
  - a) Caltrans District Materials Engineer
  - b) Nationally recognized non-Caltrans organizations such as the American Concrete Institute, Asphalt, National Institute of Certification of Engineering Technologies, etc.
  - c) Other recognized organizations approved by the State of California and/or Recognized by local governments or private associations.

Proficiency tests shall be performed for testers to be certified on Sieve Analysis, Sand Equivalent, and

Cleanness Value. All other types shall be witness tests.

A copy of each tester's current and applicable certifications shall be kept in the project files.

- 3) Laboratory and Testing Equipment— The materials laboratory shall only use laboratory and testing equipment that is in good working order. All such equipment shall be calibrated at least once each year. All testing equipment must be calibrated by impartial means using devices of accuracy traceable to the National Institute of Standards and Technology. A decal shall be firmly affixed to each piece of equipment showing the date of the last calibration. All testing equipment calibration decals shall be checked as part of the IAP.

### **Reporting Acceptance Testing Results:**

The following are time periods for reporting material test results to the Resident Engineer:

- When the aggregate is sampled at material plants, test results for Sieve Analysis, Sand Equivalent and Cleanness Value should be submitted to the Resident Engineer within 24 hours after sampling.
- When materials are sampled at the job site, test results for compaction and maximum density should be submitted to the Resident Engineer within 24 hours after sampling.
- When soils and aggregates are sampled at the job site:
  - 1) Test results for Sieve Analysis, Sand Equivalent and Cleanness Value should be submitted to the Resident Engineer within 72 hours after sampling.
  - 2) Test results for "R" Value and asphalt concrete extraction should be submitted to the Resident Engineer within 96 hours after sampling.

The reporting of AT results, if not performed by the Resident Engineer's staff, shall be done on an expedited basis such as by email or telephone.

## **2. Manufacturer's Certificate of Compliance**

### **General:**

- Various manufactured materials may be accepted for incorporation into the work without sampling or testing, on the basis of a certificate from the manufacturer.
- Where required by the contract specifications, the contractor shall submit a certificate of compliance.
- Where required by the contract, the contractor shall *attach test data or other documents* to the certificate of compliance.
- The RE may perform sampling and testing on such materials at any time.
- Certificates of compliance **shall**:
  - Be submitted by the Contractor before the material is incorporated into the work;
  - Accompany the material to the job site.
  - Identify the lot (or heat) number for each lot delivered;
  - Include the contract number;
  - Include test data and other documents if required.
  - State that the material complies with the contract specifications; and
  - Be signed by the producer of the material.

### **List of Materials Accepted by Certificate of Compliance:**

A list of materials that can be typically accepted on the basis of certificates of compliance during construction is found in Appendix F of the CT-QAP Manual. This list may be supplemented or amended by the contract Special Provisions or Technical Provisions. All certificates of compliance shall conform to the requirements of the contract specifications.



### 3. Source Inspection and Testing

- Some manufactured or pre-fabricated structural materials will be inspected or tested prior to arrival at the jobsite, generally at the manufacturer's location (source inspected.)
- Structural items categorized as "catastrophic consequences of failure" or "significant safety concern" may be source inspected. Materials that might be source inspected include structural steel, precast prestressed concrete girders and pilings, RCP greater than 60", joint seals, bearing pads, lighting and signal poles, sign structures, and electrical items.
- The RE may reject source inspected material at the job site if deemed unacceptable. For example:
  - Material damage in shipment or installation.
  - Defective material; source inspection is usually a random sampling and may not have checked 100% of the material.
- A consultant materials laboratory, qualified to perform the applicable testing, will be used to perform source inspection and testing. The consultant laboratory used will vary by project

During the Design phase of the project, the Project Engineer may submit a "Source Inspection Request" to the Agency, consultant, or Caltrans for inspection and testing of manufactured and prefabricated materials by their materials laboratory. Should the Agency request Caltrans to conduct the source inspection, and the request is accepted, all sampling, testing, and acceptance of manufactured and prefabricated materials will be performed by Caltrans' Office of Materials Engineering and Testing Services.

For Federal-aid projects on the National Highway System (NHS), Caltrans will assist in certifying the materials laboratory, and the acceptance samplers and testers. For Federal-aid projects off the NHS, Caltrans may be able to assist in certifying the materials laboratory, and the acceptance samplers and testers.

### 4. Visual Inspection

Relatively minor quantities of construction materials may be accepted without testing.

The following 3 conditions must be met:

1. Visual examination of the material is performed.
2. The manufacturer or supplier has recently furnished similar materials found to be satisfactory using normal sampling and testing requirements.
3. The manufacturer (or supplier in the case of HMA or concrete) provides certification that the material furnished complies with the contract specifications.

#### **Approximate quantities that may be accepted by visual inspection:**

- *Aggregates* other than for use in Portland Cement Concrete, not to exceed:
  - 100 tons per day, nor
  - 500 tons per project
- *Bituminous mixtures* (example: HMA), not to exceed
  - 50 tons per day.
  - If project total is less than 500 tons, sample at engineer's discretion
- *Bituminous material* (example: Liquid Asphalt), not to exceed:
  - 100 gallons per project

### C. INDEPENDENT ASSURANCE PROGRAM (IAP)

IAP shall be provided by personnel from Caltrans, the Agency's certified materials laboratory, or consultant's certified materials laboratory. IAP will be used to verify that sampling and testing procedures are being performed properly and that all testing equipment is in good condition and properly calibrated. All AT performed on the project shall use certified testing personnel and a qualified laboratory.

IAP personnel shall be certified in all required testing procedures, as part of IAP, and shall not be involved in any aspect of AT. IAP shall be performed on every type of materials test required for the project.

Poor correlation between acceptance tester's results and other test results may indicate probable deficiencies with the acceptance sampling and testing procedures. In cases of unresolved discrepancies, a complete review of AT shall be performed by IAP personnel, or an independent materials laboratory chosen by the Agency. IAP samples and tests are not to be used for determining compliance with contract requirements. Compliance with contract requirements is determined only by AT.

### D. RESIDENT ENGINEER'S CERTIFICATION OF PROJECT MATERIALS

Upon completion of a Federal-aid project, a "Materials Certificate" shall be completed by the Resident Engineer, The Agency shall include a "Materials Certificate" in the Report of Expenditures submitted to the Caltrans District Director, Attention: District Local Assistance Engineer. A copy of the "Materials Certificate" shall also be included in the Agency's construction records. The Resident Engineer in charge of the construction function for the Agency shall sign the certificate. All materials incorporated into the work which did not conform to specifications must be explained and justified on the "Materials Certification", including changes by virtue of contract change orders.

### E. PROJECT QAP RECORDS

All material records of samples and tests, material releases and certificates of compliance for the construction project shall be incorporated into the Resident Engineer's project file. If a Federal-aid project:

- The files shall be organized as described in Section 16.8 "Project Files" of the Local Assistance Procedures Manual
- It is recommended that the complete project file be available at a single location for inspection by Caltrans and Federal Highway Administration (FHWA) personnel
- The project files shall be available-for at Least three years following the date of final project voucher.
- The use of a "Log Summary," as shown in Appendix H of the CT-QAP Manual facilitates reviews of material sampling and testing by Caltrans and FHWA and assists the Resident Engineer in tracking the frequency of testing.

When two or more projects are being furnished identical materials simultaneously from the same plant, it is not necessary to take separate samples or perform separate tests for each project; however, copies of the test reports are to be provided for each of the projects to complete the records.

### APPROVED BY:



*Garrett Higerd*

(Signature)

Date: February 5, 2019

(Date Signed)

NAME: Garrett Higerd

(Print)

C70926      Exp Jun 30, 2019

(CE# and Expiration Date)

TITLE County Engineer

This page intentionally left blank

**ACCEPTANCE SAMPLING AND TESTING FREQUENCY TABLE**  
(Projects off the State Highway System)

Material	Property or Characteristic	Test Method	Frequency	Sampling Point
Excavation / Embankment	Maximum Dry Density and Optimum Moisture	ASTM D1557 (Modified Proctor) or CT 216	Minimum 1 per material/type	Representative Project location or source of material per CT 125
Subgrade	In-Place Density, Moisture content, and Relative Compaction	ASTM D6938 or CT 231	Minimum 1 test per 5000 sq ft of work area; Minimum 1 test per 2 vertical lifts	Excavation bottom, compacted lift or subgrade
Imported Borrow				
Aggregate Base	Maximum Density and Optimum Moisture	ASTM D1557 (Modified Proctor) or CT 216	Minimum 1 per material/type	Per CT 125
Subbase	Sieve Analysis	CT 202	Minimum 1 per material/type	
Asphalt Grindings	Sand Equivalent	CT 217		
	Durability Index	CT 229	At Engineer's Discretion	
	R-Value	CT 301		
	In-Place Density, Moisture content, and Relative Compaction	ASTM D6938 or CT 231	Minimum 1 test per 5000 square feet of work area; Minimum one test per Lot	In-Place Compacted Aggregate
Structure Backfill	Sieve Analysis	CT 202	Minimum 1 per material/type	Per CT 125
	Sand Equivalent	CT 217		
Select Backfill	Maximum Dry Density and Optimum Moisture	ASTM D1557 (Modified Proctor) or CT 216	Minimum 1 per material/type	Representative Project location or source of material per CT 125
	In-Place Density, Moisture content, and Relative Compaction	ASTM D6938 or CT 231	Minimum 1 test per 5000 sq ft of work area; Minimum 1 test per 2 vertical lifts	Compacted lift or subgrade
Hot Mix Asphalt	Sieve Analysis (Coldfeed, RAP)	CT 202	Minimum 1 per day for placement of 500 tons or more per day	Coldfeed / RAP at Batch Plant during production of HMA per CT 125
Asphalt Concrete	Sand Equivalent	CT 217		
	Theoretical Maximum Specific Gravity and Density	CT 309	Minimum 1 per day for placement of 500 tons or more per day	Random Location per CT 125
	Asphalt Binder Content	CT 382		
	HMA Moisture Content	CT 370		
	In-Place Density and Relative Compaction	ASTM D2950 or CT 375	Minimum of 1 test per 500 tons	In-place during final compaction at randomly determined locations
	Asphalt Binder	NA	Sample 1 Min per day for production of 500 tons or more per day; No testing required unless directed by Engineer	At Batch Plant per CT 125
	Bulk Specific Gravity and Density of Compacted Hot Mix Asphalt	CT 308	At Engineer's discretion	At randomly determined Project Location
Smoothness	12-foot Straightedge	As necessary to confirm contract compliance	Final pavement surface	

**ACCEPTANCE SAMPLING AND TESTING FREQUENCY TABLE**  
 (Projects off the State Highway System)

Material	Property or Characteristic	Test Method*	Frequency	Sampling Point
Portland Cement Concrete (Structural)	Making and Curing Concrete Cylinders	ASTM C31 or CT 540	Minimum 1 set of 5 cylinders per 100 cubic yards of concrete	Per ASTM C172 or CT 539
	Temperature	ASTM C1064 or CT 557	1 per sample	Per ASTM C172 or CT 539
	Slump	ASTM C143 or CT 556	1 per sample	Per ASTM C172 or CT 539
	Air Entrainment	ASTM C231 or CT 504	Minimum 1 per sample if concrete mix design specifies air entrainment	Per ASTM C172 or CT 539
	Unit Weight	ASTM C138 or CT 518	1 per sample	Per ASTM C172 or CT 539
	Compressive Strength	ASTM C39 or CT 521	7 days and 28 days**	NA

\* American Concrete Institute (ACI) provides certification to perform the relevant ASTM test methods and practices.

\*\* If the concrete mix design contains fly ash or similar additive, frequency shall be 7 days and 42 days.

ACI - American Concrete Institute

ASTM - American Society for Testing and Materials

CT - Caltrans Test Method

# **SECTION IV**



## **PROJECT PLANS**

**MONO COUNTY CIVIC CENTER  
TOP LIFT ASPHALT PAVING PROJECT**

**PROJECT NO. MCCC PAVING**

This page intentionally left blank

ONE AND ONE-HALF INCH = ONE FOOT  
 ONE INCH = ONE FOOT  
 THREE-QUARTERS INCH = ONE FOOT  
 ONE-HALF INCH = ONE FOOT  
 ONE-QUARTER INCH = ONE FOOT  
 ONE-EIGHTH INCH = ONE FOOT  
 ONE-SIXTEENTH INCH = ONE FOOT  
 ONE INCH = TWENTY FEET

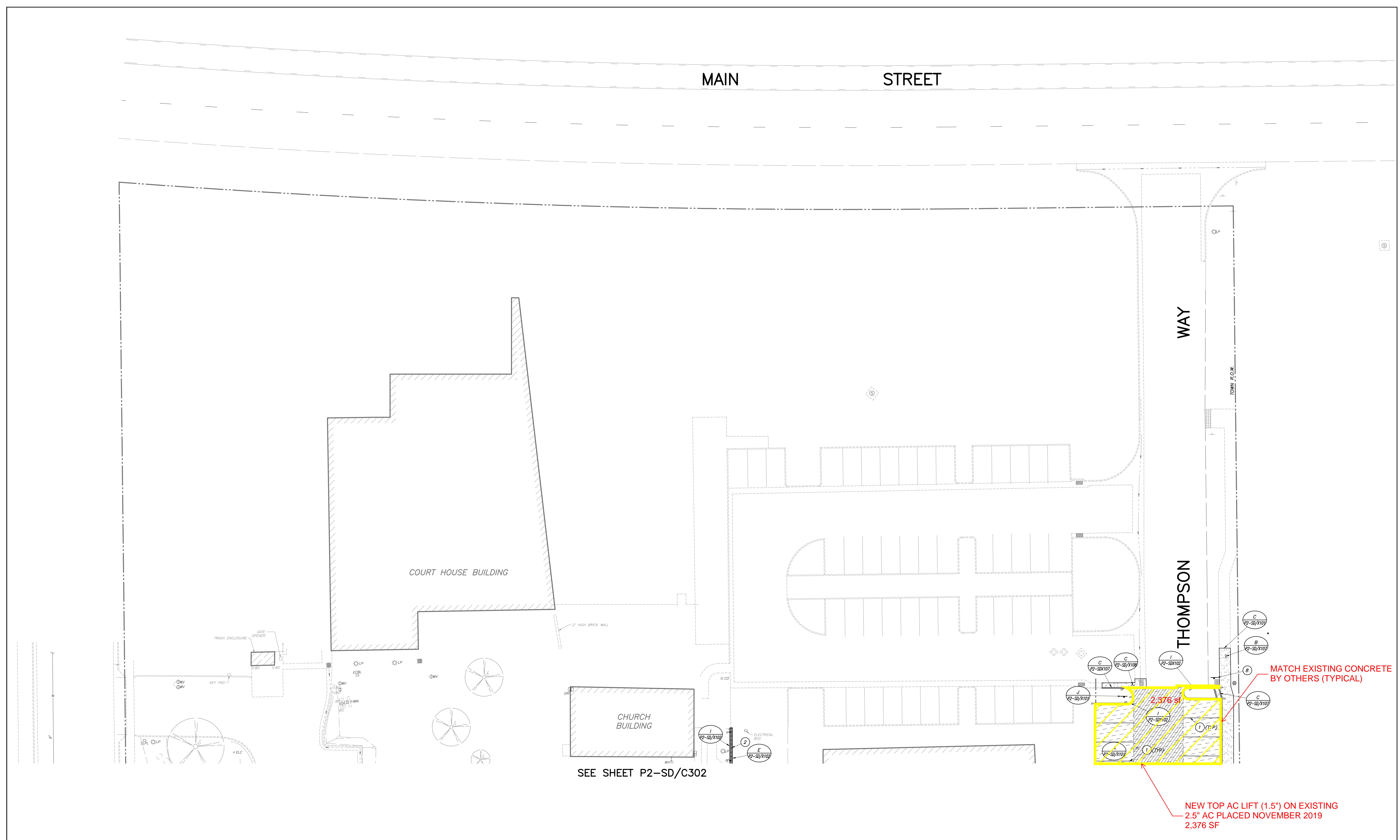

- SITE LEGEND:**
- LIMITS OF STANDARD DUTY CONCRETE IMPROVEMENTS
  - LIMITS OF HEAVY DUTY CONCRETE PAVEMENT STRUCTURAL SECTION PER [0/P2-SD/X102]
  - LIMITS OF HEAVY DUTY ASPHALTIC CONCRETE PAVEMENT STRUCTURAL SECTION
  - LIMITS OF STANDARD DUTY ASPHALTIC CONCRETE PAVEMENT STRUCTURAL SECTION
  - DETECTABLE WARNINGS PER [1/P2-SD/X101]
  - LIMITS OF PAINTED CURB
  - BOLLARD PER [A/P2-SD/X102]
  - SNOW POLE AND SLEEVE PER [C/P2-SD/X107]
  - PLANTER
  - RIGHT OF WAY
  - PARKING STALL COUNT

Mono County - Civic Center  
 SIERRA PARK ROAD, TOWN OF MAMMOTH LAKES, CALIFORNIA  
 MONO COUNTY PUBLIC WORKS

**Roebelen**  
 QUALITY CONSTRUCTION SINCE 1959  
 INSTITUTIONAL • COMMERCIAL • INDUSTRIAL

8/15/2019 Date Signed

**Blair Church & Flynn**  
 CONSULTING ENGINEERS  
 465 Clovis Avenue, Suite 200  
 Clovis, California 93602  
 Tel: (559) 328-5100 Fax: (559) 328-5100

**nacht&lewis**  
 CONSULTANT  
 600 O Street, Suite 100  
 Sacramento, CA 95811  
 www.nachtlewis.com  
 P 916.329.4000

ARCHITECT  
 CONSTRUCTION DOCUMENTS

NO.	DESCRIPTION	DATE
1	AGENCY REVIEW	5/17/19
2	GENERATOR	4/24/19
6	AGENCY REVIEW	5/3/19
15	ADJACENT PROPERTY	8/15/19
17	INFILTRATION SYSTEM	7/26/19

DATE AUGUST 15, 2019  
 JOB NO. Y183600  
 SHEET TITLE

SITE PLAN

SHEET NO. P2-SD/C301  
 SHEET \_\_\_ OF \_\_\_ TOTAL

**811**  
 Know what's below.  
 Call before you dig.  
 PACKAGE 2



ONE AND ONE-HALF INCH = ONE FOOT  
 ONE INCH = ONE FOOT  
 THREE-QUARTERS INCH = ONE FOOT  
 ONE-HALF INCH = ONE FOOT  
 ONE-FOURTH INCH = ONE FOOT  
 ONE-EIGHTH INCH = ONE FOOT  
 ONE-SIXTEENTH INCH = ONE FOOT  
 ONE INCH = TWENTY FEET

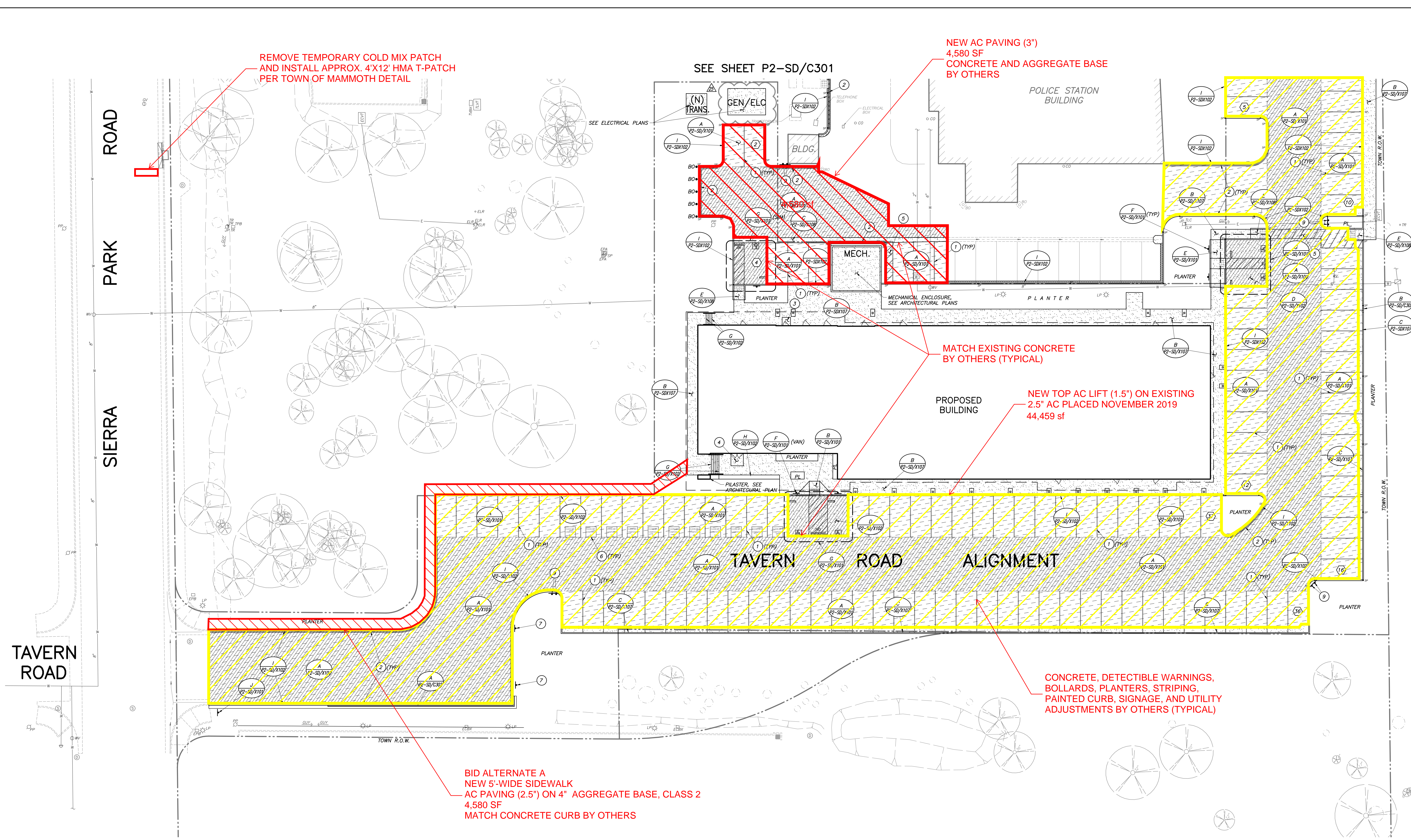

**SITE LEGEND:**

- LIMITS OF STANDARD DUTY CONCRETE IMPROVEMENTS
- LIMITS OF HEAVY DUTY CONCRETE PAVEMENT STRUCTURAL SECTION PER [D/P2-SD/X102]
- LIMITS OF HEAVY DUTY ASPHALTIC CONCRETE PAVEMENT STRUCTURAL SECTION
- LIMITS OF STANDARD DUTY ASPHALTIC CONCRETE PAVEMENT STRUCTURAL SECTION
- DETECTABLE WARNINGS PER [I/P2-SD/X101]
- LIMITS OF PAINTED CURB
- BOLLARD PER [A/P2-SD/X102]
- SNOW POLE AND SLEEVE PER [C/P2-SD/X107]
- PLANTER
- R.O.W.
- PARKING STALL COUNT

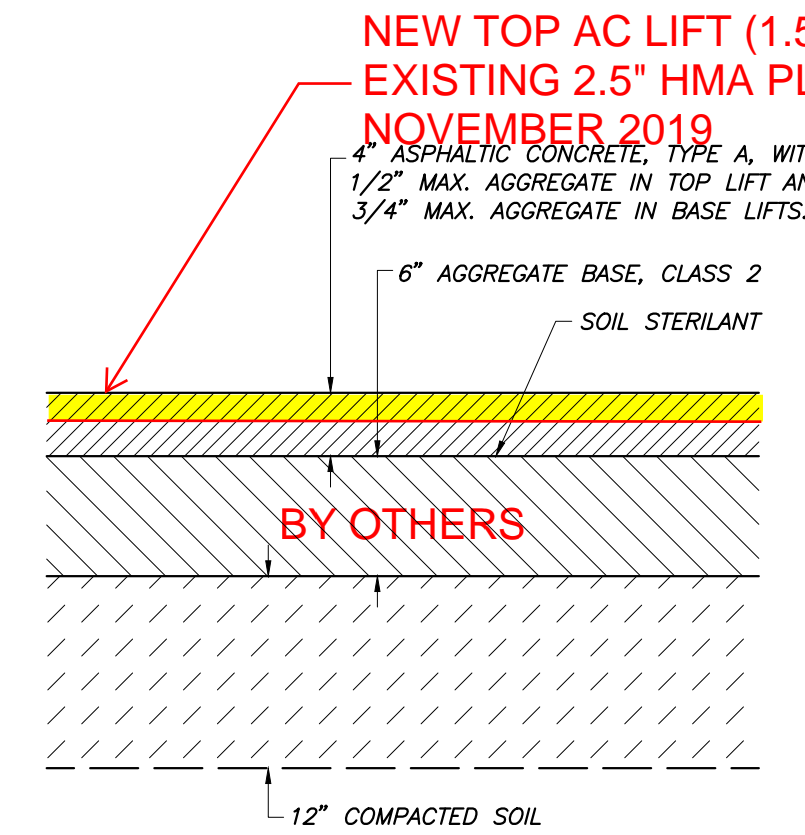

**NEW TOP AC LIFT (1.5") SECTION**

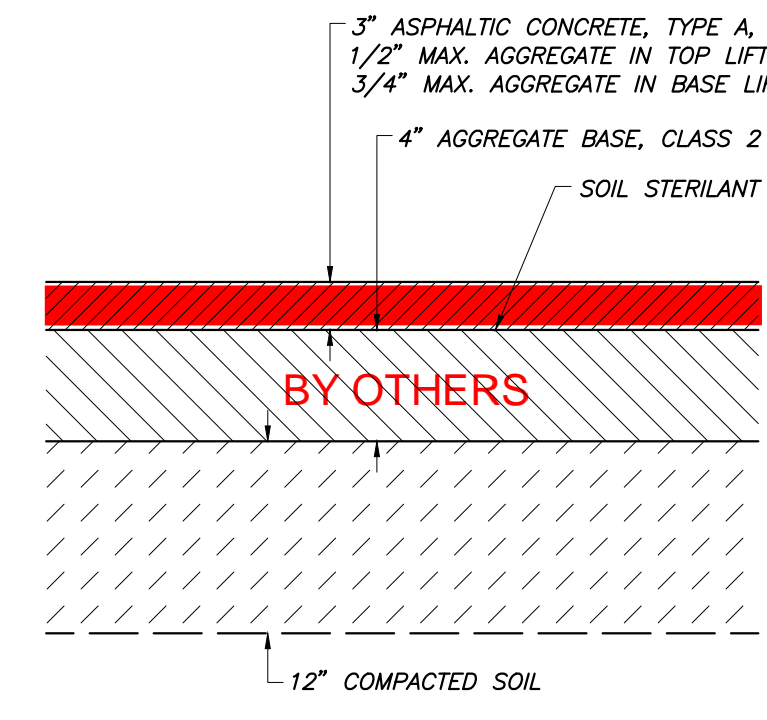

**NEW AC PAVING (3") SECTION**

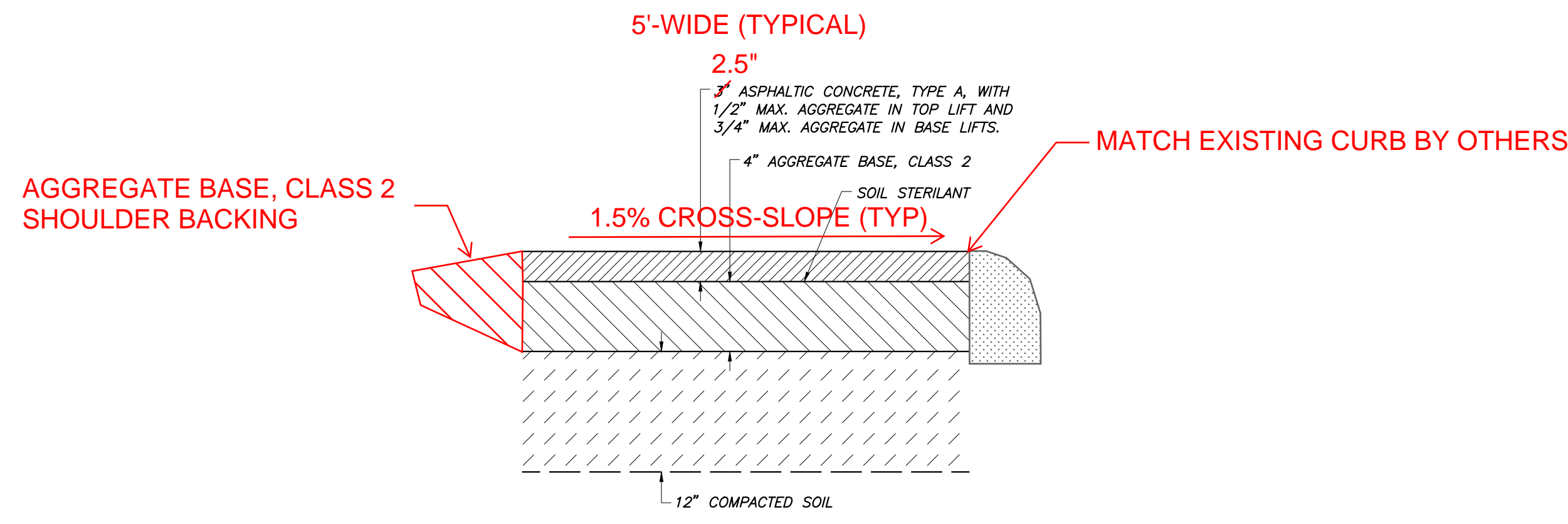

**BID ALTERNATE A - NEW AC SIDEWALK (2.5") SECTION**

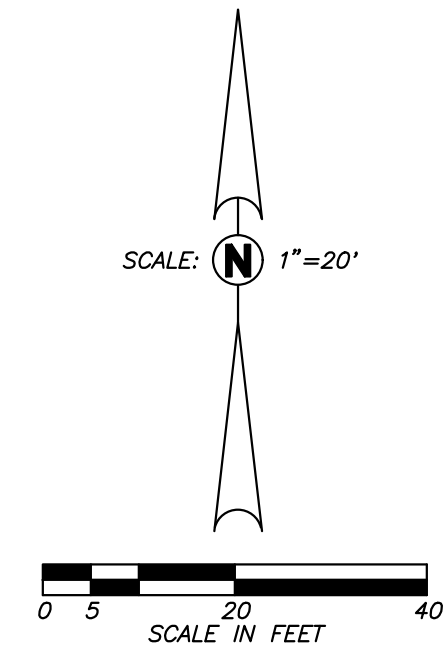

Mono County - Civic Center  
 SIERRA PARK ROAD, TOWN OF MAMMOTH LAKES, CALIFORNIA  
 MONO COUNTY PUBLIC WORKS

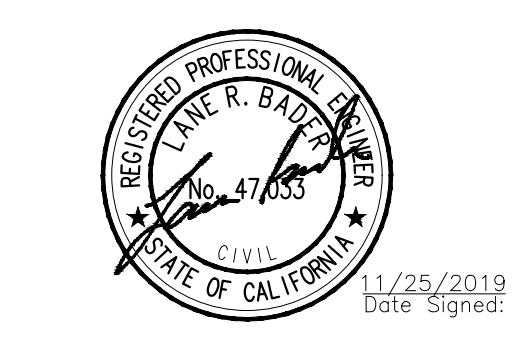

**Blair Church & Flynn**  
 CONSULTING ENGINEERS  
 455 Clovis Avenue, Suite 200  
 Clovis, California 95625  
 Tel: (509) 528-5400 Fax: (509) 528-5300

**nacht&lewis**  
 CONSULTANT  
 600 O Street, Suite 100  
 Sacramento, CA 95811  
 www.nachtlewis.com  
 P 916.329.4000

**ARCHITECT**

**CONSTRUCTION DOCUMENTS**

NO.	DESCRIPTION	DATE
1	AGENCY REVIEW	5/17/19
2	GENERATOR	4/24/19
6	AGENCY REVIEW	5/3/19
15	ADJACENT PROPERTY	8/15/19
17	INFILTRATION SYSTEM	9/19/19
25	UTILITY CONFLICT	11/25/19

DATE NOVEMBER 25, 2019  
 JOB NO. Y183600  
 SHEET TITLE

**SITE PLAN**

SHEET NO.  
 P2-SD/C302  
 SHEET \_\_\_ OF \_\_\_ TOTAL

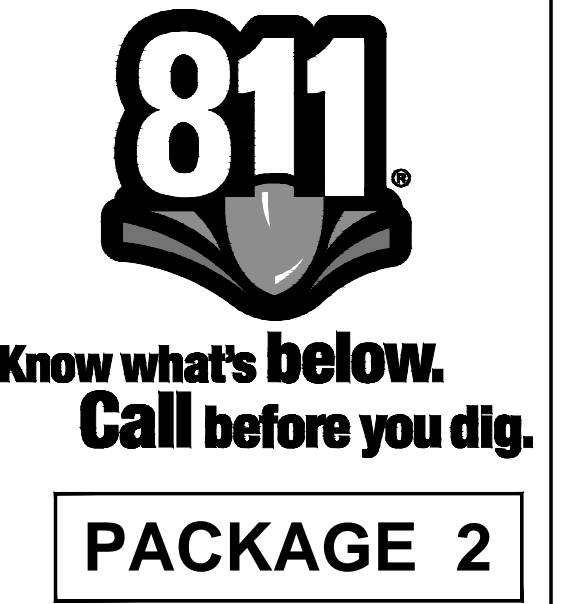

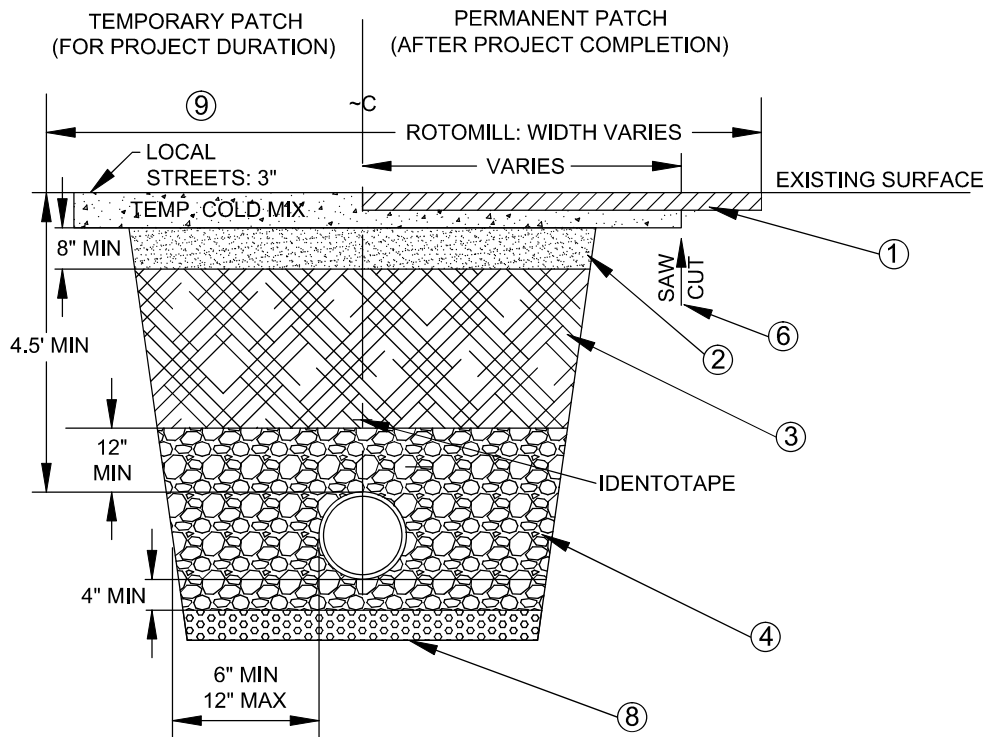

**CONSTRUCTION NOTES FOR A.C. TRENCH PATCH:**

1. PERMANENT AC INSTALLATION:
  - A. ROTOMILL MINIMUM 2 INCHES DEEP TO COVER ALL AREAS OF CRACKED OR RAVELED SURFACES DISTURBED BY TRENCHING.
  - B. TACK COAT SC-3000 AND/OR HOT MIX IF FULLY CURED OR IF CONDITIONS WARRANT ON ALL EDGES AND MILLED SURFACES.
  - C. AC PAVEMENT SHALL CONFORM TO STANDARD 006-0 OF THESE STANDARDS.
2. AGGREGATE BASE PER STANDARD 006 OF THESE STANDARDS. BASE SHALL NOT BE REQUIRED WHEN USING CONCRETE SLURRY FOR BACKFILL.
3. TRENCH BACKFILL SHALL BE PER TOWN STANDARD 202-0, OR IMPORTED FILL AS APPROVED BY PUBLIC WORKS DIRECTOR. NATIVE MATERIAL AND IMPORTED FILL SHALL BE COMPACTED TO 95% MAXIMUM DENSITY PER ASTM D 1557.
4. PIPE BEDDING SHALL BE GRANULAR MATERIAL (3/4 INCH MAX) COMPACTED TO 90% PER ASTM D-1557 OR SLURRY. ALL BEDDING SHALL HAVE A NON-WOVEN GEOTEXTILE ON ALL SIDES.
5. TRANSVERSE: FOR ALL STREETS, THE TRENCH WIDTH SHALL BE TRENCH WIDTH PLUS 9 INCH (EACH SIDE) OR 24 INCH MINIMUM TOTAL PATCH WIDTH, WHICHEVER IS GREATER.
6. SAW CUT EDGE SHALL BE PARALLEL OR PERPENDICULAR TO TRENCH (TYP.).
7. PAVEMENT PATCH DEPTH IS TO MATCH CONTIGUOUS PAVEMENT, BUT NOT LESS THAN 3 INCHES (5-1/2 INCHES ON ARTERIAL AND COLLECTOR STREETS).
8. OVER EXCAVATE WHEN TRENCH BOTTOM IS SATURATED. REPLACE WITH 3-6 INCH ROCK TO A MIN 6 INCH DEPTH. WRAP WITH NON-WOVEN CLASS 3 (AASHTO M288 96) GEOTEXTILE ON ALL SIDES.
9. A MINIMUM 2 INCH THICK TEMPORARY PATCH OF COLD MIX ASPHALT CONCRETE SHALL BE PLACED AND COMPACTED IMMEDIATELY AFTER COMPLETION OF UNDERGROUND WORK OR AT END OF THE WORKDAY, OR COVERED WITH PLATING AS APPROVED BY THE EXCAVATION PERMIT INSPECTOR OR APPLICABLE ENGINEER OF RECORD. IF NOT PATCHED WITHIN 24 HOURS AFTER BACKFILLING, THE TOWN MAY PATCH AND BACK-CHARGE THE PERMITEE FOR ALL COSTS. TEMPORARY PATCH SHALL BE SET TO BETWEEN 1/8 AND 1/4 INCHES ABOVE EXISTING SURFACE.

**TOWN OF MAMMOTH LAKES - DEPARTMENT OF PUBLIC WORKS**



**A.C. TRENCH PATCH**

PUBLIC WORKS DIRECTOR APPROVAL: *[Signature]*

DATE: **May 7, 2014**

STANDARD PLAN

**201-2**

SHEET 3 OF 5

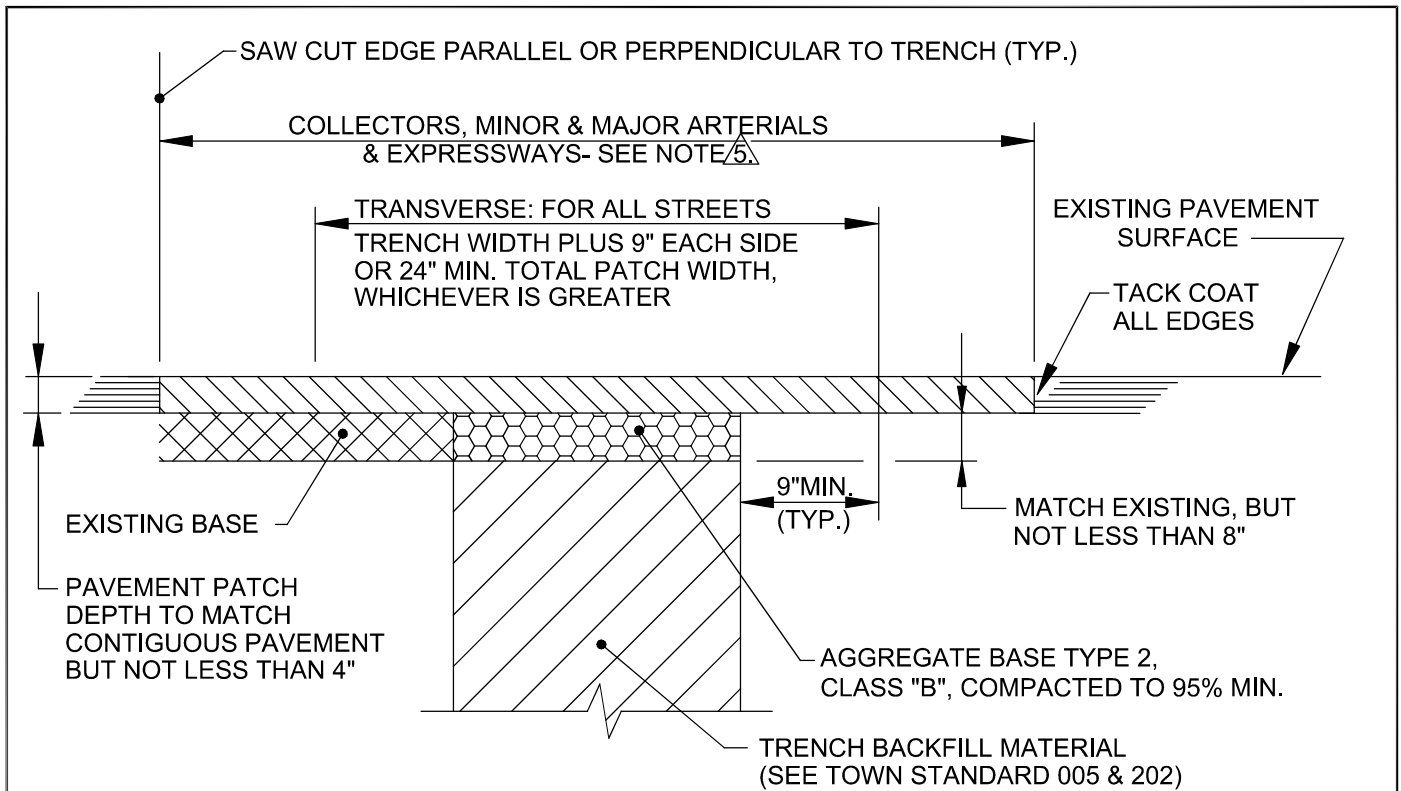

### PERMANENT BITUMINOUS PAVEMENT PATCH

**NOTES:**

1. A PERMIT MUST BE OBTAINED FROM THE PUBLIC WORKS DIRECTOR PRIOR TO CUTTING ANY PUBLIC RIGHT-OF-WAY. 24 HOURS PRIOR TO TRENCH EXCAVATION, THE PERMITTEE MUST NOTIFY THE PUBLIC WORK INSPECTOR OR APPLICABLE ENGINEER OF RECORD.
2. ALL PERMANENT PATCH WORK SHALL BE THE RESPONSIBILITY OF THE CONTRACTOR, THROUGHOUT THE DURATION OF THE WARRANTY IN ACCORDANCE WITH MUNICIPAL CODE CHAPTER 1204.
3. IF SAW CUT IS WITHIN 2 FEET OF AN EXISTING PAVEMENT EDGE OR EXISTING PAVEMENT PATCH, REMOVE EXISTING PAVEMENT TO THAT EDGE AND REPLACE ENTIRE SECTION.
4. ALL A.C. REPLACEMENT REQUIREMENTS ARE MINIMUM WIDTHS ONLY. THE PUBLIC WORKS DIRECTOR MAY REQUIRE WIDER PATCH SECTIONS OR OTHERWISE ALTER THESE REQUIREMENTS.
5. LONGITUDINAL TRENCH PATCH WIDTH:  
FOR COLLECTORS, MINOR AND MAJOR ARTERIALS AND EXPRESSWAYS: IF SAW CUT EDGES FOR LONGITUDINAL OR TRANSVERSE EXCAVATIONS FALL WITHIN A TRAVEL LANE, SAW CUT SHALL BE EXTENDED TO, AND REMOVAL MADE TO EDGE OF THE TRAVEL LANE, OR THE FULL DEPTH PATCH SHALL BE MADE PER THE SPECIFICATIONS FOR TRANSVERSE PATCHES AND THE ENTIRE TRAVEL LANE ROTOMILLED TO A DEPTH OF TWO INCHES AND OVERLAYED WITH TWO INCHES OF BITUMINOUS PLANT MIX AS DIRECTED BY THE ENGINEER.
6. EDGE OF 4 INCH ROCK WHEEL TRENCHES FOR CONDUIT SHALL BE LOCATED A MINIMUM OF 9 INCHES FROM GUTTER LIP AND SHALL BE PATCHED AS PER THE ABOVE DETAIL.
7. AGGREGATE BASE AND BITUMINOUS PAVEMENT SHALL BE IN ACCORDANCE WITH STANDARD SPECIFICATIONS FOR PUBLIC WORKS CONSTRUCTION, LATEST REVISION.
8. CONTRACTOR SHALL BE RESPONSIBLE FOR REPLACEMENT OF LOOP DETECTORS, ADJUSTMENT OF UTILITIES AND SURVEY MONUMENTS TO GRADE AND INSTALLATION OF TEMPORARY PAVEMENT MARKERS.
9. FOR P.C.C. CURB REPLACEMENT, SAW CUT EXISTING PAVEMENT 18 INCHES MIN. FROM GUTTER LIP LINE, REMOVE AND REPLACE PAVEMENT TO SAW CUT EDGES. CONCRETE MAY BE POURED NEAT AGAINST EXISTING EDGE OF ASPHALT IF APPROVED BY THE PUBLIC WORKS DIRECTOR.

**TOWN OF MAMMOTH LAKES - DEPARTMENT OF PUBLIC WORKS**



## A.C. TRENCH PATCH

PUBLIC WORKS DIRECTOR APPROVAL: *[Signature]*

DATE: **May 7, 2014**

STANDARD PLAN

**201-1**

SHEET 4 OF 5



**OFFICE OF THE CLERK  
OF THE BOARD OF SUPERVISORS**

**SPECIAL MEETING AGENDA REQUEST**

Print

<b>MEETING DATE</b>	March 26, 2020	<b>DEPARTMENT</b>
<b>ADDITIONAL DEPARTMENTS</b>		
<b>TIME REQUIRED</b>		<b>PERSONS APPEARING BEFORE THE BOARD</b>
<b>SUBJECT</b>	Closed Session - Exposure to Litigation	

**AGENDA DESCRIPTION:**

(A brief general description of what the Board will hear, discuss, consider, or act upon)

CONFERENCE WITH LEGAL COUNSEL – ANTICIPATED LITIGATION. Significant exposure to litigation pursuant to paragraph (2) of subdivision (d) of Government Code section 54956.9. Number of potential cases: two.

**RECOMMENDED ACTION:**

**FISCAL IMPACT:**

**CONTACT NAME:**

**PHONE/EMAIL:** /

SUBMIT THE ORIGINAL DOCUMENT WITH ATTACHMENTS TO THE OFFICE OF THE COUNTY ADMINISTRATOR  
**PRIOR TO 5:00 P.M. ON THE FRIDAY  
32 DAYS PRECEDING THE BOARD MEETING**

**SEND COPIES TO:**

**MINUTE ORDER REQUESTED:**

YES  NO

**ATTACHMENTS:**

<a href="#">Click to download</a>
No Attachments Available

**History**

Time	Who	Approval
3/24/2020 3:14 PM	County Administrative Office	Yes

3/19/2020 10:36 AM

County Counsel

Yes

3/19/2020 4:28 PM

Finance

Yes



**OFFICE OF THE CLERK  
OF THE BOARD OF SUPERVISORS**

***SPECIAL MEETING AGENDA REQUEST***

Print

<b>MEETING DATE</b>	March 26, 2020	<b>DEPARTMENT</b>	
<b>ADDITIONAL DEPARTMENTS</b>			
<b>TIME REQUIRED</b>	15 minutes	<b>PERSONS APPEARING BEFORE THE BOARD</b>	Stacey Simon, County Counsel
<b>SUBJECT</b>	Urgency Ordinance Adding Chapter 7.93 to the Mono County Code Temporarily Prohibiting Residential or Commercial Evictions		

**AGENDA DESCRIPTION:**

(A brief general description of what the Board will hear, discuss, consider, or act upon)

The ordinance presented to your Board today adds Chapter 7.93 to the Mono County Code to temporarily prohibit (until May 31, 2020, unless extended) residential or commercial evictions arising from income loss or substantial medical expenses related to the COVID-19 pandemic. As drafted, Chapter 7.93 does not relieve a tenant from the obligation to pay rent or restrict a landlord's ability to recover rent that is due and requires tenants seeking protection under Chapter 7.93 to thoroughly document their hardship.

**RECOMMENDED ACTION:**

Adopt proposed ordinance ORD20-\_\_, Adding Chapter 7.93 to the Mono County Code to prohibit residential or commercial evictions through May 31, 2020, arising from income loss or substantial medical expenses related to the corona virus pandemic.

**FISCAL IMPACT:**

None.

**CONTACT NAME:** Stacey Simon

**PHONE/EMAIL:** x1704 / ssimon@mono.ca.gov

SUBMIT THE ORIGINAL DOCUMENT WITH ATTACHMENTS TO THE OFFICE OF THE COUNTY ADMINISTRATOR  
**PRIOR TO 5:00 P.M. ON THE FRIDAY  
32 DAYS PRECEDING THE BOARD MEETING**

**SEND COPIES TO:**

**MINUTE ORDER REQUESTED:**

YES  NO

**ATTACHMENTS:**

**Click to download**

[Staff Report](#)

[Ordinance](#)

[Exhibit A](#)

---

**History**

<b>Time</b>	<b>Who</b>	<b>Approval</b>
3/23/2020 1:41 PM	County Administrative Office	Yes
3/19/2020 2:47 PM	County Counsel	Yes
3/19/2020 4:30 PM	Finance	Yes

**County Counsel**  
Stacey Simon

**Assistant County Counsels**  
Christian E. Milovich  
Anne L. Frievault

**Deputy County Counsel**  
Jason Canger

**OFFICE OF THE  
COUNTY COUNSEL**

*Mono County*  
South County Offices  
P.O. BOX 2415  
MAMMOTH LAKES, CALIFORNIA 93546

**Telephone**  
760-924-1700

**Facsimile**  
760-924-1701

**Paralegal**  
Jenny Lucas

To: Board of Supervisors

From: Office of the Mono County Counsel

Date: March 26, 2020

Re: Urgency ordinance adding Chapter 7.93 to the Mono County Code to temporarily prohibit residential or commercial evictions arising from income loss or substantial medical expenses related to the COVID-19 pandemic.

**Strategic Plan Focus Areas Met**

Economic Base     Infrastructure     Public Safety  
 Environmental Sustainability     Mono Best Place to Work

**Recommended Action:** Approve and adopt ordinance.

**Fiscal Impact:** No impact imposed by the adoption of the ordinance.

**Discussion**

On March 16, 2020, Governor Newsom issued Executive Order N-28-20, which, among other things, authorizes local governments to halt evictions for renters under certain circumstances. In response, various municipalities across the State are enacting temporary moratoriums on residential and commercial evictions related to financial impacts caused by the COVID-19 pandemic. The moratoriums are intended to prevent any resident from being evicted due to a loss of income related to a business closure, loss of hours or wages, layoffs, or out-of-pocket medical costs caused by the pandemic.

The ordinance presented to your Board today adds Chapter 7.93 to the Mono County Code to temporarily prohibit (until May 31, 2020, unless extended) residential or commercial evictions arising from income loss or substantial medical expenses related to the COVID-19 pandemic. As drafted, Chapter 7.93 does not relieve a tenant from the obligation to pay rent or restrict a landlord's ability to recover rent that is due and requires tenants seeking protection under Chapter 7.93 to thoroughly document their hardship.



The ordinance, if approved, would take effect immediately as an urgency ordinance pursuant to Government Code section 25123(d) and upon the finding of the Board that it is necessary for the protection of the public peace, health and safety, and that it is necessary to prevent the County of Mono from suffering potentially irreversible displacement of tenants resulting from the evictions that this ordinance is designed to prevent.

If you have any questions regarding this item prior to your meeting, please call Christian Milovich at 760-924-1706.



ORDINANCE NO. ORD20-\_\_

**AN ORDINANCE OF THE MONO COUNTY BOARD OF SUPERVISORS ADDING  
CHAPTER 7.93 TO THE MONO COUNTY CODE TO PROHIBIT RESIDENTIAL  
OR COMMERCIAL EVICTIONS THROUGH MAY 31, 2020, ARISING  
FROM INCOME LOSS OR SUBSTANTIAL MEDICAL EXPENSES  
RELATED TO THE CORONA VIRUS PANDEMIC**

**WHEREAS**, on March 4, 2020, Governor Newsom issued a Proclamation of a State of Emergency in the State of California related to the COVID-19 pandemic; and

**WHEREAS**, on March 15, 2020, the Mono County Health Officer declared a local health emergency related to the COVID-19 pandemic. The declaration was ratified by the Mono County Board of Supervisors on March 17, 2020, and the Board also declared a state of emergency under the California Emergency Services Act; and

**WHEREAS**, in light of the COVID-19 pandemic and the state of emergency proclamation, on March 16, 2020, the Governor issued Executive Order N-28-20, which order is attached hereto as Exhibit A and incorporated by this reference, suspending any provision of state law prohibiting local government from exercising its police power to impose substantive limitations on residential or commercial evictions; and

**WHEREAS**, on March 17, 2020, the Mono County Health Officer ordered the closure of all local bars, cessation of in-room dining in restaurants and a prohibition of non-essential public gatherings; and

**WHEREAS**, the COVID-19 pandemic and associated public health orders are expected to result in the closure of many local businesses until such time as these orders are lifted, and result in extreme restrictions on other local businesses until then, and possibly thereafter; and

**WHEREAS**, the COVID-19 pandemic and associated public health orders are expected to result in a severe loss of income to a widespread portion of the local population that depend on wages or business income to pay rent and result in substantial medical expenses for certain Mono County residents; and

**WHEREAS**, Mono County is experiencing a housing affordability crisis, which was driving displacement of residents even prior to the COVID-19 pandemic; and

**WHEREAS**, many Mono County renters are rent-burdened, paying large percentages of their income on rent, which leaves less money for families to spend on other necessities like food, healthcare, transportation, and education; and

**WHEREAS**, evictions due to the COVID-19 pandemic, if not protected against, present an immediate threat to the public peace, health and safety as described in Government Code

1 section 25123(d) in that they will cause the displacement of residents and contribute to an ever  
2 increasing housing crisis; and

3 **WHEREAS**, the Board has determined that it is appropriate to temporarily prohibit  
4 evictions, through May 31, 2020, for any tenant (residential or commercial) who can demonstrate  
5 that they are being evicted for the failure to pay rent, and that such failure is a direct impact of  
6 the COVID-19 pandemic; and

7 **WHEREAS**, there is an urgent need for the County of Mono to enact such substantive  
8 limitations to protect the health, safety and welfare of its citizens in light of the emergency  
9 declared by the State and County regarding the COVID-19 pandemic.

10 **NOW, THEREFORE**, the Board of Supervisors of the County of Mono ordains that:

11 **SECTION I**

12 Chapter 7.93 is hereby added to the Mono County Code, to read as follows:

13 **Chapter 7.93**

14 **PROHIBITION ON EVICTIONS ARISING FROM SUBSTANTIAL INCOME  
15 LOSS OR MEDICAL EXPENSES RELATED TO THE CORONAVIRUS PANDEMIC**

16 Sections:

17 **7.93.010 Purpose.**

18 **7.93.020 Definitions.**

19 **7.93.030 Prohibition on evictions stemming from coronavirus pandemic losses.**

20 **7.93.040 Enforcement and Penalties.**

21 **7.93.050 Severability.**

22 **7.93.010 Purpose.**

23 Pursuant to the general police power of the County to protect the health, safety and  
24 welfare of its citizens, this chapter prohibits evictions through May 31, 2020, for any tenant  
25 leasing property located within the unincorporated areas of Mono County who can demonstrate  
26 that they have received a notice of eviction for failure to pay rent, and that such failure is related  
27 to a substantial loss of income or substantial out-of-pocket medical expenses resulting from the  
28 2020 novel coronavirus pandemic or any local, state, or federal government response to the  
29 pandemic.

30 **7.93.020 Definitions.**

31 The following words and phrases, whenever used in this chapter, shall be construed as  
32 defined in this section.

(A) "Commercial real property" means any real property that is used for business or  
income-producing purposes.

(B) "Owner" means any person, acting as principal or through an agent, providing  
residential or commercial real property for rent, and includes a predecessor in interest to the  
owner.

1 (C) "Residential real property" means any dwelling or unit that is intended or used for  
2 human habitation.

3 (D) "Tenancy" means the lawful occupation of residential or commercial real property  
4 and includes a lease or sublease.

5 **7.93.030 Prohibition on evictions stemming from coronavirus pandemic losses.**

6 (A) Through May 31, 2020, the owner of residential or commercial real property shall  
7 not terminate a tenancy for failure to pay rent if the tenant demonstrates that the failure to pay  
8 rent is directly related to a substantial loss of income or substantial out-of-pocket medical  
9 expenses associated with the coronavirus pandemic or any local, state, or federal government  
10 response to the pandemic.

11 (B) In order for this section to apply, a tenant must demonstrate through documentation  
12 or other objectively verifiable means:

13 (1) Substantial loss of income from (a) job loss; (b) layoff; (c) a reduction in the  
14 number of compensable hours of work; (d) a store, restaurant, office, or business closure; (e) a  
15 substantial decrease in business income caused by a reduction in opening hours or consumer  
16 demand; (f) the need to miss work to care for a home-bound school-age child or a family  
17 member infected with coronavirus; or (g) other similarly-caused loss of income that resulted  
18 from the pandemic; or

19 (2) Substantial out-of-pocket medical expenses related to the pandemic.

20 (C) This prohibition shall also apply to an owner's action that constitutes constructive  
21 eviction under California law. An owner's failure to comply with this ordinance shall render any  
22 notice of termination of tenancy void. This section may be asserted as an affirmative defense in  
23 an unlawful detainer action. Terminations that are required to comply with an order issued by a  
24 government agency or court requiring that the real property be vacated are excepted from this  
25 prohibition. An owner's failure to comply with this ordinance does not constitute a criminal  
26 offense but will subject an owner to civil fines and penalties as outlined more specifically in  
27 section 7.93.040.

28 (D) Nothing in this ordinance shall relieve a tenant of the obligation to pay rent, nor  
29 restrict a landlord's ability to recover rent due.

30 (E) This ordinance shall be liberally construed to provide the broadest possible  
31 protection for tenants in the unincorporated area of the County.

32 **7.93.040 Enforcement and Penalties.**

(A) The remedies provided by this chapter are cumulative and in addition to any other  
remedies available at law or in equity.

(B) Any violation of this chapter may be enforced through administrative citation and  
penalty as provided in Chapter 1.12 of the Mono County Code except that the amount of the  
administrative penalty shall be one thousand dollars per day.

(C) Each and every violation of this chapter, or applicable state law or regulation shall  
constitute a separate violation per day and shall be subject to all remedies and enforcement

1 measures authorized by the Mono County Code or otherwise authorized by law. Additionally,  
2 any violation shall be subject to injunctive relief, disgorgement to the county of any and all  
3 monies unlawfully obtained, costs of abatement, costs of restoration, costs of investigation,  
4 restitution, and any other relief or remedy available at law or in equity. The county, including the  
5 office of the district attorney and the office of the county counsel, may pursue any and all  
6 remedies and actions available and applicable under state and local laws for any violations.

7 **7.93.050 Severability.**

8 If any provision of this ordinance is found to be unconstitutional or otherwise invalid by  
9 any court of competent jurisdiction, that invalidity shall not affect the remaining provisions of  
10 this ordinance which can be implemented without the invalid provisions, and to this end, the  
11 provisions of this ordinance are declared to be severable. The Board of Supervisors hereby  
12 declares that it would have adopted this ordinance and each provision thereof irrespective of  
13 whether any one or more provisions are found invalid, unconstitutional or otherwise  
14 unenforceable.

15 **SECTION II**

16 This ordinance is not subject to the California Environmental Quality Act (CEQA)  
17 pursuant to CEQA Guidelines Section 15060(c)(2) (the activity will not result in a direct or  
18 reasonably foreseeable indirect physical change in the environment) and Section 15060(c)(3)  
19 (the activity is not a project as defined in Section 15378 of the CEQA Guidelines, because it has  
20 no potential for resulting in physical change to the environment, directly or indirectly.)

21 **SECTION III**

22 Effective Date. This ordinance shall take effect immediately as an urgency ordinance.  
23 This is based on the Board of Supervisors finding that this ordinance is adopted in compliance  
24 with Government Code Section 25123(d), that it is necessary for the protection of the public  
25 peace, health and safety for the reasons contained in the findings set forth at the beginning of this  
26 ordinance, which are incorporated by reference herein, and that it is necessary to prevent the  
27 County of Mono from suffering potentially irreversible displacement of tenants resulting from  
28 the evictions that this ordinance is designed to prevent.

29 //

30 //

31 //

32 //

//

//

//

//

1 **PASSED, APPROVED and ADOPTED** this 26<sup>th</sup> day of March, 2020, by the following  
2 vote, to wit:

3 **AYES:**  
4 **NOES:**  
5 **ABSENT:**  
6 **ABSTAIN:**

7  
8  
9 \_\_\_\_\_  
10 Stacy Corless, Chair  
11 Mono County Board of Supervisors

12 ATTEST:

13 APPROVED AS TO FORM:

14 \_\_\_\_\_  
15 Clerk of the Board

16 \_\_\_\_\_  
17 County Counsel

EXECUTIVE DEPARTMENT  
STATE OF CALIFORNIA

EXECUTIVE ORDER N-28-20

**WHEREAS** on March 4, 2020, I proclaimed a State of Emergency to exist in California as a result of the threat of COVID-19; and

**WHEREAS** despite sustained efforts, the virus remains a threat, and further efforts to control the spread of the virus to reduce and minimize the risk of infection and otherwise mitigate the effects of COVID-19 are needed; and

**WHEREAS** the economic impacts of COVID-19 have been significant, and could threaten to undermine Californians' housing security and the stability of California businesses; and

**WHEREAS** many Californians are experiencing substantial losses of income as a result of business closures, the loss of hours or wages, or layoffs related to COVID-19, hindering their ability to keep up with their rents, mortgages, and utility bills; and

**WHEREAS** Californians who are most vulnerable to COVID-19, those 65 years and older, and those with underlying health issues, are advised to self-quarantine, self-isolate, or otherwise remain in their homes to reduce the transmission of COVID-19; and

**WHEREAS** because homelessness can exacerbate vulnerability to COVID-19, California must take measures to preserve and increase housing security for Californians to protect public health; and

**WHEREAS** local jurisdictions, based on their particular needs, may therefore determine that additional measures to promote housing security and stability are necessary to protect public health or to mitigate the economic impacts of COVID-19; and

**WHEREAS** local jurisdictions may also determine, based on their particular needs, that promoting stability amongst commercial tenancies is also conducive to public health, such as by allowing commercial establishments to decide whether and how to remain open based on public health concerns rather than economic pressures, or to mitigate the economic impacts of COVID-19; and

**WHEREAS** in addition to these public health benefits, state and local policies to promote social distancing, self-quarantine, and self-isolation require that people be able to access basic utilities—including water, gas, electricity, and telecommunications—at their homes, so that Californians can work from home, receive public health information, and otherwise adhere to policies of social distancing, self-quarantine, and self-isolation, if needed; and

**WHEREAS** many utility providers, public and private, covering electricity, gas, water, and sewer, have voluntarily announced moratoriums on service disconnections and late fees for non-payment in response to COVID-19; and

**WHEREAS** many telecommunication companies, including internet and cell phone providers, have voluntarily announced moratoriums on service disconnections and late fees for non-payment in response to COVID-19;

**NOW, THEREFORE, I, GAVIN NEWSOM**, Governor of the State of California, in accordance with the authority vested in me by the State Constitution and statutes of the State of California, and in particular, Government Code sections 8567 and 8571, do hereby issue the following order to become effective immediately:

**IT IS HEREBY ORDERED THAT:**

- 1) The time limitation set forth in Penal Code section 396, subdivision (f), concerning protections against residential eviction, is hereby waived. Those protections shall be in effect through May 31, 2020.
- 2) Any provision of state law that would preempt or otherwise restrict a local government's exercise of its police power to impose substantive limitations on residential or commercial evictions as described in subparagraphs (i) and (ii) below—including, but not limited to, any such provision of Civil Code sections 1940 et seq. or 1954.25 et seq.—is hereby suspended to the extent that it would preempt or otherwise restrict such exercise. This paragraph 2 shall only apply to the imposition of limitations on evictions when:
  - (i) The basis for the eviction is nonpayment of rent, or a foreclosure, arising out of a substantial decrease in household or business income (including, but not limited to, a substantial decrease in household income caused by layoffs or a reduction in the number of compensable hours of work, or a substantial decrease in business income caused by a reduction in opening hours or consumer demand), or substantial out-of-pocket medical expenses; and
  - (ii) The decrease in household or business income or the out-of-pocket medical expenses described in subparagraph (i) was caused by the COVID-19 pandemic, or by any local, state, or federal government response to COVID-19, and is documented.

The statutory cause of action for judicial foreclosure, Code of Civil Procedure section 725a et seq.; the statutory cause of action for unlawful detainer, Code of Civil Procedure section 1161 et seq., and any other statutory cause of action that could be used to evict or otherwise eject a residential or commercial tenant or occupant of residential real property after foreclosure is suspended only as applied to any tenancy, or residential real property and any



occupation thereof, to which a local government has imposed a limitation on eviction pursuant to this paragraph 2, and only to the extent of the limitation imposed by the local government.

Nothing in this Order shall relieve a tenant of the obligation to pay rent, nor restrict a landlord's ability to recover rent due.

The protections in this paragraph 2 shall be in effect through May 31, 2020, unless extended.

- 3) All public housing authorities are requested to extend deadlines for housing assistance recipients or applicants to deliver records or documents related to their eligibility for programs, to the extent that those deadlines are within the discretion of the housing authority.
- 4) The Department of Business Oversight, in consultation with the Business, Consumer Services, and Housing Agency, shall engage with financial institutions to identify tools to be used to afford Californians relief from the threat of residential foreclosure and displacement, and to otherwise promote housing security and stability during this state of emergency, in furtherance of the objectives of this Order.
- 5) Financial institutions holding home or commercial mortgages, including banks, credit unions, government-sponsored enterprises, and institutional investors, are requested to implement an immediate moratorium on foreclosures and related evictions when the foreclosure or foreclosure-related eviction arises out of a substantial decrease in household or business income, or substantial out-of-pocket medical expenses, which were caused by the COVID-19 pandemic, or by any local, state, or federal government response to COVID-19.
- 6) The California Public Utilities Commission is requested to monitor measures undertaken by public and private utility providers to implement customer service protections for critical utilities, including but not limited to electric, gas, water, internet, landline telephone, and cell phone service, in response to COVID-19, and on a weekly basis publicly report these measures.

Nothing in this Order shall be construed to invalidate any limitation on eviction enacted by a local jurisdiction between March 4, 2020 and this date.

Nothing in this Order shall in any way restrict state or local authority to order any quarantine, isolation, or other public health measure that may compel an individual to remain physically present in a particular residential real property.

This Order is not intended to, and does not, create any rights or benefits, substantive or procedural, enforceable at law or in equity, against the State of California, its agencies, departments, entities, officers, employees, or any other person.

**I FURTHER DIRECT** that as soon as hereafter possible, this proclamation be filed in the Office of the Secretary of State and that widespread publicity and notice be given of this Order.

**IN WITNESS WHEREOF** I have hereunto set my hand and caused the Great Seal of the State of California to be affixed this 16th day of March 2020.



\_\_\_\_\_  
GAVIN NEWSOM  
Governor of California

**ATTEST:**

\_\_\_\_\_  
ALEX PADILLA  
Secretary of State